

Installation Manual

VHF RADIO TELEPHONE

Model FM-8900S

SAFETY INSTRUCTIONS	i
SYSTEM CONFIGURATION	ii
EQUIPMENT LISTS	iii
1. HOW TO INSTALL THE EQUIPMENT	1
1.1 Transceiver Unit FM-8900S	1
1.2 VHF Antenna	2
1.3 CH70 RX Antenna	3
1.4 Handset Hanger	3
1.5 AC-DC Power Supply Unit PR-240	3
1.6 Printer	4
1.7 Printer Interface IF-8500	4
1.8 Loudspeaker SEM-21Q	4
1.9 Junction Box IF-8900	5
1.10 Remote Station RB-8900, Watertight Remote Station RB-8900-W	6
1.11 VHF Console RC-8900	7
2. CONNECTIONS	8
2.1 Power Supply	8
2.2 VHF Antenna	9
2.3 CH70 RX Antenna	9
2.4 Handset HS-2003	9
2.5 How to Ground the Transceiver Unit.....	9
2.6 Junction Box	10
2.7 How to Connect the Remote Station without the Junction Box.....	12
2.8 AC/DC Power Supply Unit PR-240	13
2.9 When the Handset HS-2003 is not Connected to the Transceiver Unit.....	14
2.10 Rainproof Cover for Transceiver Unit	14
2.11 Jumper Setting for Termination.....	15
2.12 VHF Console.....	16
2.13 I/O Data.....	17
3. HOW TO ASSEMBLE THE VHF CONSOLE KIT	18
4. INITIAL SETTINGS	21
4.1 How to Register the MMSI and ATIS ID	21
4.2 Service Menu	22
4.3 Settings Inside the Transceiver Unit	25
APPENDIX 1 JIS CABLE GUIDE	AP-1
PACKING LISTS	A-1
OUTLINE DRAWINGS	D-1
INTERCONNECTION DIAGRAMS	S-1

ECF

(Elemental Chlorine Free)

The paper used in this manual
is elemental chlorine free.

FURUNO ELECTRIC CO., LTD.

9-52 Ashihara-cho,
Nishinomiya, 662-8580, JAPAN

• FURUNO Authorized Distributor/Dealer

All rights reserved. Printed in Japan

Pub. No. IME-56800-J

(GREG) FM-8900S

A : APR. 2012

J : MAR. 12, 2018



0 0 0 1 7 6 2 0 3 1 8



SAFETY INSTRUCTIONS

WARNING



HAZARDOUS VOLTAGE.
Can shock, burn or cause serious injury.

Do not work inside the equipment unless totally familiar with electrical circuits.



Do not approach the antenna closer than the distances shown below when the antenna is transmitting.

The antenna emits radio waves that can be harmful to the human body.

RF power density on antenna aperture	Distance	Description required by
100 W/m ²	0.12 m	IEC 60945
10 W/m ²	0.39 m	IEC 60945
2 W/m ²	0.89 m	MPE by FCC

(MPE: Minimum Permissible Exposure)



Turn off the power at the mains switch-board before beginning the installation.
Post a warning sign near the switch-board to indicate that power should not be applied while the equipment is being installed.

Electrical shock, serious injury or fire can result if the power is not turned off or is applied while the equipment is being installed.

CAUTION



Ground the transceiver unit.

Ground the transceiver unit to prevent electrical shock and interference.



Confirm that the power supply voltage is compatible with the voltage rating of the equipment.

Connection to the wrong power supply can cause fire or damage the equipment.



Follow the compass safe distances to prevent interference to a magnetic compass.

	Standard compass	Steering compass
FM-8900S	0.50m	0.30m
IF-8900	2.05m	1.35m
HS-2003	1.50m	0.95m
HS-8900	0.45m	0.30m
HS-8900-W	0.45m	0.30m
HG-8900	1.75m	1.20m
HG-8900-W	1.70m	1.10m
RB-8900	1.40m	0.90m
RB-8900-W	1.40m	0.90m
PR-240	0.90m	0.60m
IF-8500	1.05m	0.70m
SEM-21Q	2.20m	1.50m
RC-8900	2.20m	1.40m

SYSTEM CONFIGURATION

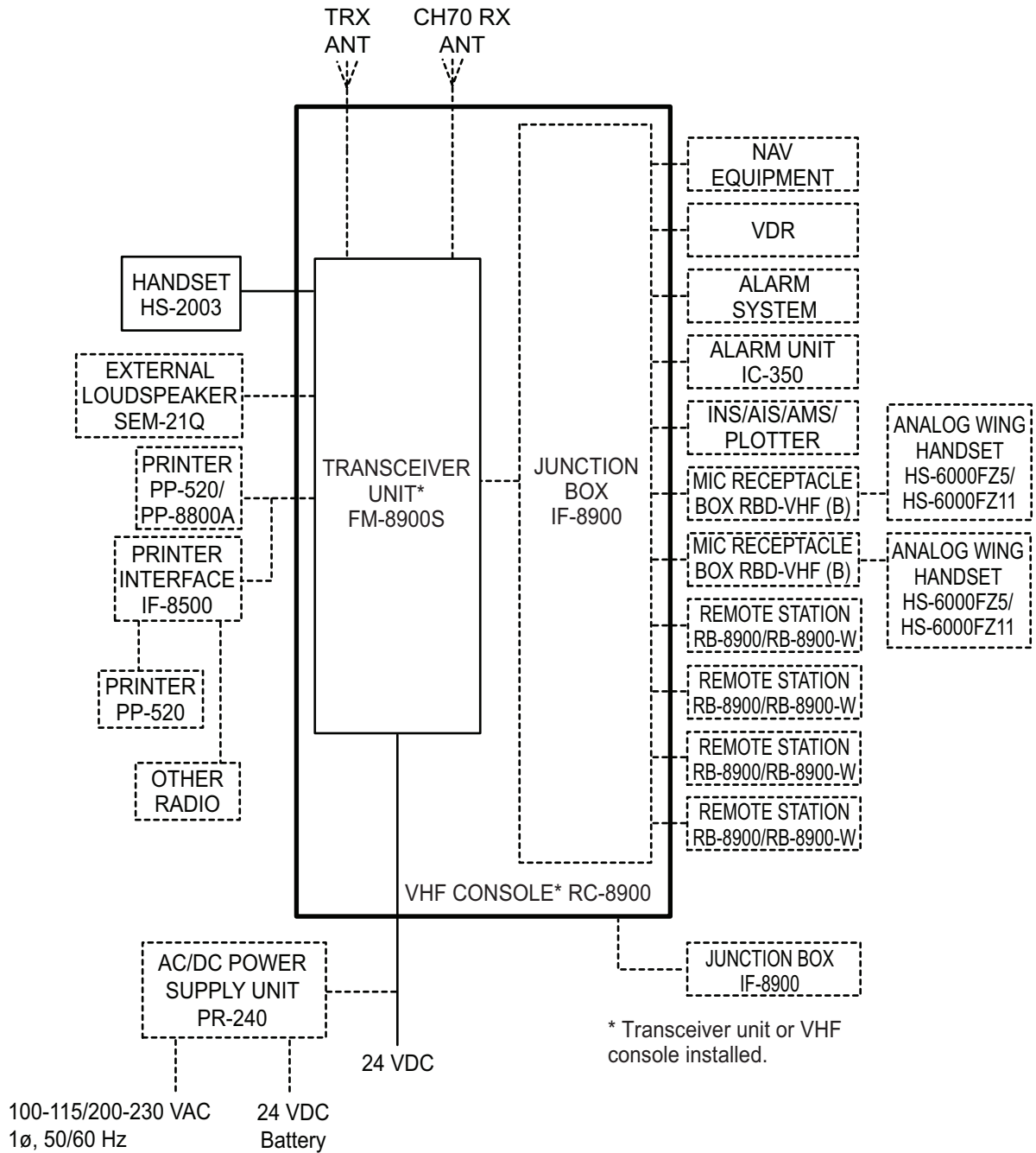

Environmental category

Antenna units: Exposed to the weather

All other units: Protected from the weather

EQUIPMENT LISTS

Standard supply

Name	Type	Qty	Remarks
Transceiver Unit	FM-8900S	1	Select one
Installation Materials	CP05-12600	1 set	For transceiver unit w/inst. mat. CP05-12601, cable assy. LP-02-1(7A)-L3000
Accessories	FP05-05730	1 set	For HS-2003-15
	FP05-05720		For HS-2003-15-L
Spare Parts	SP05-06201	1 set	For transceiver unit Fuse (Type: FGBO 125V 7A PDF, Code No.: 000-155-831-10)

Standard supply (for VHF console RC-8900)

Name	Type	Qty	Remarks
VHF Console	RC-8900-N	1	No printer
	RC-8900-A		With printer
Installation Materials	CP05-13101	1 set	For VHF console
Accessories	FP05-05740	1 set	For HS-2003-20-L
	FP05-05750		

Optional equipment

Name	Type	Code no.	Remarks
Junction Box	IF-8900	-	w/Inst. mat. CP05-12701
Remote Station	RB-8900-15	-	Remote handset HS-8900-15, Handset hanger HG-8900, w/Inst. mat. CP05-12801
Remote Station	RB-8900-20	-	Remote handset HS-8900-20, Handset hanger HG-8900, w/Inst. mat. CP05-12801
Watertight Remote Station	RB-8900-W-15	-	Waterproof handset HS-8900-W-15, Waterproof handset hanger HG-8900-W, w/Inst. mat. CP05-12801
Remote Handset	HS-8900-15	000-020-890	
Remote Handset	HS-8900-20	000-020-891	
Watertight Remote Handset	HS-8900-W-15	000-020-924	
Handset Hanger	HG-8900	000-020-892	
Watertight Handset Hanger	HG-8900-W	000-020-925	
Flush Mount Kit	OP05-129	000-020-883	
Hanger Kit	OP05-132	000-020-884	Hanger for transceiver unit, w/accessories
Waterproof Seal	OP05-133	001-174-890	For Junction Box IF-8900, to comply with waterproofing std.

EQUIPMENT LISTS

Name	Type	Code no.	Remarks
Rainproof Cover	OP05-134	001-178-740	For transceiver unit
External Loud-speaker	SEM-21Q	001-165-970-10	
Dynamic Mic. Set	OP05-57	000-045-775	Receptacle Box: RBD-VHF(B)-75BG Hanger: AP-102 Handset: HS-6000FZ5 (dynamic mic., curled cable)
Handset Set	OP05-42	000-045-778	Receptacle Box: RBD-VHF(B)-75BG Hanger: AP-102 Handset: HS-6000FZ11 (dynamic mic., straight cable)
MIC Receptacle Box	RBD-VHF(B)-75BG	000-056-094	
Handset Hanger	AP-102	001-081-320-10	
Handset	HS-6000FZ11	000-135-072-10	
Handset	HS-6000FZ5	000-112-623-10	
Recording Paper	TP058-30CL	001-097-110	08S0378 W: 57 mm, L: 30 m
Printer	PP-520	-	
Ribbon Cartridge	7Q1VP80SF	001-198-190-10	
Printer Interface	IF-8500	000-053-895	
Handset	HS-2003-15	000-021-369	w/1.5 m cable, straight connector
Handset	HS-2003-15-L	000-021-367	w/1.5 m cable, elbow connector
Handset	HS-2003-20-L	000-021-368	w/2 m cable, elbow connector
Handset	HS-2003-20	000-054-390	w/ 2m cable
Handset	HS-2003-50S	000-054-391	w/5 m straight cable
Handset Hanger	FP05-05510	005-951-790	For HS-2003
AC/DC Power Supply	PR-240	-	
Antenna	CX4-3/FEC	000-193-422-10	
	FAB-151D	001-144-490-10	
Connector	AP05-01001	005-389-790	
Antenna Fixing Bracket	N173/FEC	001-474-350	For CX4-3/FEC (ϕ 49 to 90)
	N174/FEC	001-494-890	For CX4-3/FEC (ϕ 30 to 61)
	CP05-14001	001-430-360	Bracket M-15AS1
Printer	PP-8800A	-	w/power cable
Emergency Lamp	NLFL-03W-WB	000-176-706-10	For rack console
Cable Assy	PG05-0053-1	000-158-681-11	Extension cable for HS-2003
Coaxial Cable	RG-10/U-Y *10M*	000-159-411-10	
Coaxial Cable	RG-10/U-Y *20M*	000-159-412-10	
Coaxial Cable	RG-10/U-Y *30M*	000-159-413-10	
Coaxial Cable	RG-10/U-Y *40M*	000-159-414-10	
Coaxial Cable	RG-10/U-Y *50M*	000-159-415-10	
Console Kit	RC-8900-A-T	-	Console: RC-8900-A-T Inst. Mat.: CP05-13201 Accessories: FP05-06801 (No printer) FP05-06800 (With printer)

1. HOW TO INSTALL THE EQUIPMENT

This chapter shows you how to install the units of the system. The transceiver unit and handset are standard supply. All other units are optional supply. (The junction box is standard supply in some installations.)

1.1 Transceiver Unit FM-8900S

1.1.1 General installation remarks

The transceiver unit can be installed on a desktop (with hanger), under a desktop, overhead, bulkhead, or in a console (requires a flush mount kit). Select a location where the controls can be easily operated and a location that is near the power source and the ground location. Additionally, select a location that meets the following conditions:

- Select a location away from water spray and water splash.
- All outdoor installed connectors on coaxial cables should be fitted with preventive isolation such as vulcanizing tape to protect against water penetration into the antenna cable. Also, apply marine sealant at the antenna base to prevent water intrusion from the screw part of antenna base.
- The location must not be in direct sunlight, because of heat that can increase inside the unit.
- Leave some additional length in cables to allow a service technician to move the radio from its normal location with the cables connected.
- Do not install the unit where flammable gases are stored.
- Select a location that provides good ventilation.
- Make sure the location can hold the weight of the unit under the condition of continued vibration normally found on the ship. If necessary, strengthen the location. For added support use nuts, bolts and washers (instead of self-tapping screws) to fasten the unit.
- Leave enough space at the sides and rear of the unit for maintenance and service purposes and to provide cool air. See the outline drawings at the back of this manual for recommended service space.
- For Solas Convention vessels, the mounting location must satisfy the conditions of Regulations 22 Navigation bridge visibility.
- For installation in a console, select a location where the display can be easily seen.
- The transceiver unit causes interference to a magnetic compass if put too close to the compass. Follow the compass safe distance in the safety instructions to prevent interference to a magnetic compass.

1.1.2 Desktop, bulkhead, overhead installation

1. Use the hanger as a template to mark the fixing holes in the installation location.
2. Fix the hanger to the location with the self-tapping screws and washers (supplied). **(For the overhead mount, use nuts, bolts and washers instead of the self-tapping screws.)**
3. Screw the knob bolts with the washers into the transceiver unit.
4. Set the transceiver unit to the hanger and tighten the knob bolts.

1. HOW TO INSTALL THE EQUIPMENT

1.1.3 Console installation (flush mount, option)

Requires the optional flush mount kit (OP05-129), the contents of which are shown in the table below. Follow the instructions in the outline drawing to install the unit in a console.

Name	Type	Code no.	Qty
Mounting Plate	05-104-2603	100-370-030-10	1
Self-tapping Screw	5×20	000-802-081	4
Hex Screw	M8×16	000-882-075	2

1.2 VHF Antenna

1.2.1 Requirements for the antenna

Any good quality antenna that meets the requirements shown below can be used.

- Frequency range: 155 to 164 MHz
- Impedance: 50 ohms
- Polarization: Vertical
- Handling power: 30 W
- Quality: Withstand the marine environment

1.2.2 Installation location

The location and installation of different antennas on a ship is important to ensure effective communications. Incorrectly installed antennas will degrade performance of the radio equipment and reduce the range of communications.

Select the location for the antenna considering the following points.

- VHF antennas should be placed in a position which is as elevated and free as possible, with at least 2 meters horizontal separation from constructions made by conductive materials.
- Ideally there should not be more than one antenna on the same level.
- The location of mandatory VHF antennas should be given priority compared with mobile telephone antennas. If they are located on the same level, the distance between them should be at least 5 meters.

1.2.3 Mounting procedure

The basic mounting procedure for the antennas supplied by FURUNO is as follows; however, consult appropriate outline drawing for details.

1. Fasten the antenna bracket to the stanchion.
2. Set the antenna to the antenna bracket and tighten bolts.
3. Screw the coaxial cable plug into the antenna.

1.3 CH70 RX Antenna

The antenna must be separated from the antennas, masts, and other objects that can cause interference. Follow the recommended separation distances in section 1.2.2. The installation procedure is like that for the VHF antenna. See the outline drawing.

1.4 Handset Hanger

Install the handset hanger to the left of the transceiver unit. The location must provide easy access to the front panel controls while you operate the handset. The length of the standard handset cable is 50 cm. Put the handset hanger within 50 cm of the unit. (Longer cables are available.)

1.5 AC-DC Power Supply Unit PR-240

For Solas Convention vessels, both AC and DC power must be supplied to the transceiver unit, through an AC/DC power supply. When the AC input fails, DC power is supplied. FURUNO can supply an AC/DC power supply unit, the PR-240. Provide protective earth. See chapter 2.

1.5.1 Installation location

Select the location that meets the following conditions:

- Select a location that provides good ventilation.
- The location must be clean and dry.
- Make sure the location can hold the weight of the unit under the condition of continued vibration normally found on the ship.
- The power supply unit will affect the performance of a magnetic compass if put near the compass. Follow the compass safe distance in the safety instructions to prevent the interference to a magnetic compass.

1. HOW TO INSTALL THE EQUIPMENT

1.6 Printer

1.6.1 Printer PP-520

See the outline drawing for installation instructions.

1. Decide the location for the printer.
2. Set the ink ribbon cartridge and the roll paper to the printer. See the PP-520's Operator's Manual for the procedures.
3. Set the fixtures (left/right) to the printer, and fasten them with four self-tapping screws ($\phi 5 \times 20$).

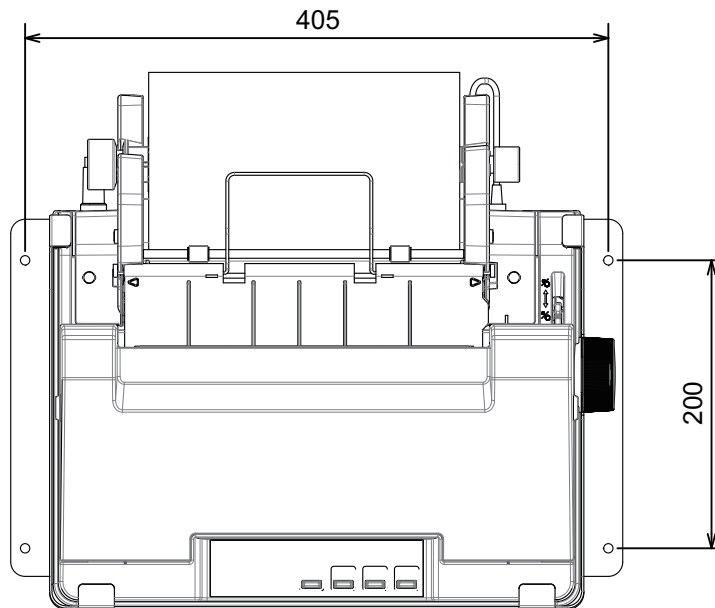

1.6.2 Printer PP-8800A

See the outline drawing at the back of this manual for information. This printer cannot be connected to the Printer Interface IF-8500.

1. Make a cutout of 208(W) \times 133(H) mm in the mounting location.
2. Set the printer to the cutout and fasten the printer with four self-tapping screws (4 \times 16).

1.7 Printer Interface IF-8500

The Printer Interface IF-8500 allows the FM-8900S and other MF/HF radio communication equipment to share the Printer PP-520. See the outline drawing at the back of this manual for installation instructions.

1.8 Loudspeaker SEM-21Q

The loudspeaker can be installed on a desktop, the overhead or a bulkhead. Fasten the loudspeaker with the self-tapping screws, or nuts, bolts and washers. See the outline drawing at the back of this manual for dimensions.

1.9 Junction Box IF-8900

The junction box can be mounted on a desktop or bulkhead, and is required to connect the remote station, wing handset, etc. Put the unit within 5 m of the transceiver unit, because that is the length of the cable connected between the units.

For the bulkhead mount, it is necessary to cover holes in the bottom of the unit to comply with the Ingress Protection Rating IPx2. Waterproof seals (Type: OP05-133, Code no.: 001-174-890) are optionally available for this purpose. Set them to the open holes on the underside of the junction box as shown below, BEFORE installing the junction box.

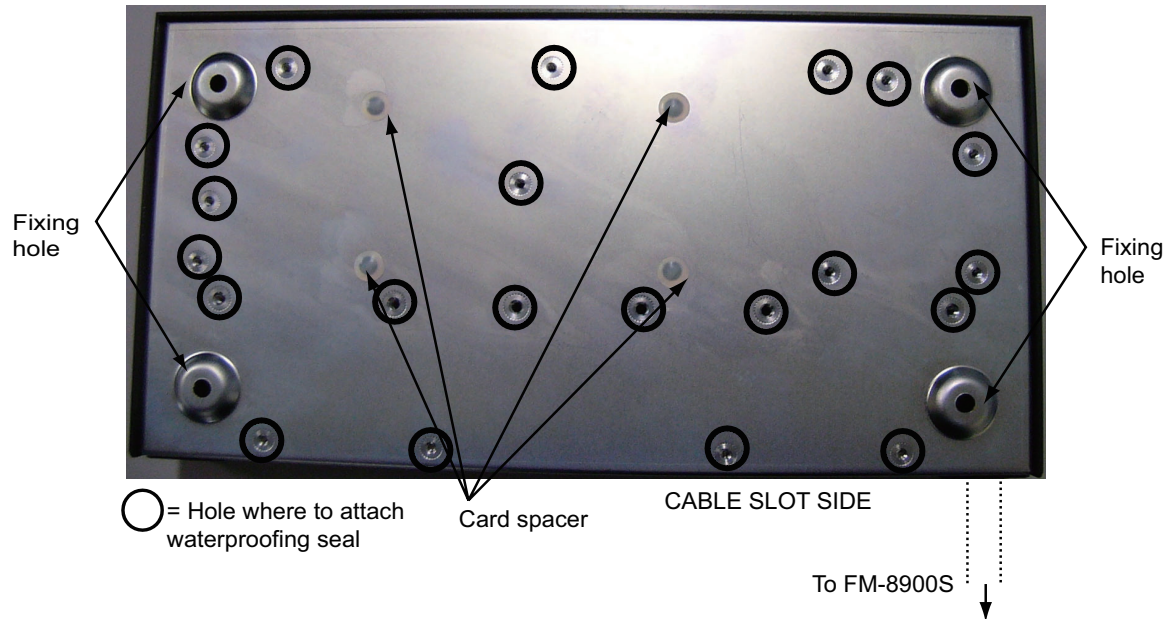

To install the junction box, open the cover and fasten the box with four self-tapping screws (5×20). Close the cover.

1. HOW TO INSTALL THE EQUIPMENT

1.10 Remote Station RB-8900, Watertight Remote Station RB-8900-W

A maximum of four remote stations can be installed.

1. Remove six screws on the handset hanger.
2. Remove upper chassis of the hanger.
3. Fasten the base of the hanger to a bulkhead with two self-tapping screws (4×20).
4. Connect the cables to the remote station then assemble the remote station.

1.10.1 How to install the Watertight Remote Station outdoors

The Watertight Remote Station RB-8900-W (with Watertight Remote Handset HS-8900-W) can be installed outside if it is contained in a waterproof enclosure. As shown below, apply the silicone sealant to the hanger to waterproof the hanger.

Be sure to put the RB-8900-W in a waterproof enclosure when the unit is installed outside. The waterproofing category of the RB-8900-W is IEC 60529 IP56. However, protect the unit from the weather (IEC 60945).

Before you close the hanger with the silicone sealant (for waterproofing), do the termination setting (only for termination device, see section 2.11) and connect the cables. Do not open the hanger after it has been sealed.

1. Fasten the mounting base with the self-tapping screws. Apply the silicone sealant to the exposed part of those screws.
2. Attach the cable from the transceiver unit or junction box. Apply the silicone sealant to the cable around the cable entrance.
3. Confirm that the plastic washers are in the screw holes. Fasten the cover of the handset hanger. Apply the silicone sealant to the junction between the mounting base and the cover.

2. Apply silicone sealant to cable entrance.

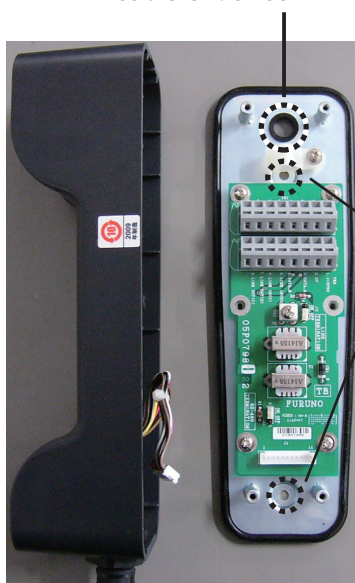

1. Apply silicone sealant to self-tapping screws.



3. Apply silicone sealant to junction.



1.11 VHF Console RC-8900

Install the VHF console where you can easily operate the equipment in the console and do maintenance and service. Meet with shipyard personnel and ship's officer-in-charge to select the best location. The location must meet the following points:

- Select a location where you can operate controls easily.
- Select a location where shock and vibration are the least possible.
- Select a location away from water splash and rain.
- The temperature and humidity of the location must be both stable and moderate.

How to install the console

1. Ask shipyard personnel to tighten six M5 nuts or six M5 bolts to the fixing holes (on the bulkhead), referring to the outline drawing at the back of this manual.
2. Unfasten the cover assembly from the console.
3. Set the VHF console to the bolts.
4. Fasten the console with the bolts or nuts and weld nuts to the bulkhead.
5. Fasten the cover assembly to the console.
Note: To connect wires after you have hung the console, see section 2.12.
6. Fasten the handset hanger with two screws.
7. To fasten the optional emergency lamp, connect the cable to the terminal board, then fasten the lamp to the console. Refer to the interconnection diagram and outline drawing.

2. CONNECTIONS

Connect external equipment at the rear of the transceiver unit.

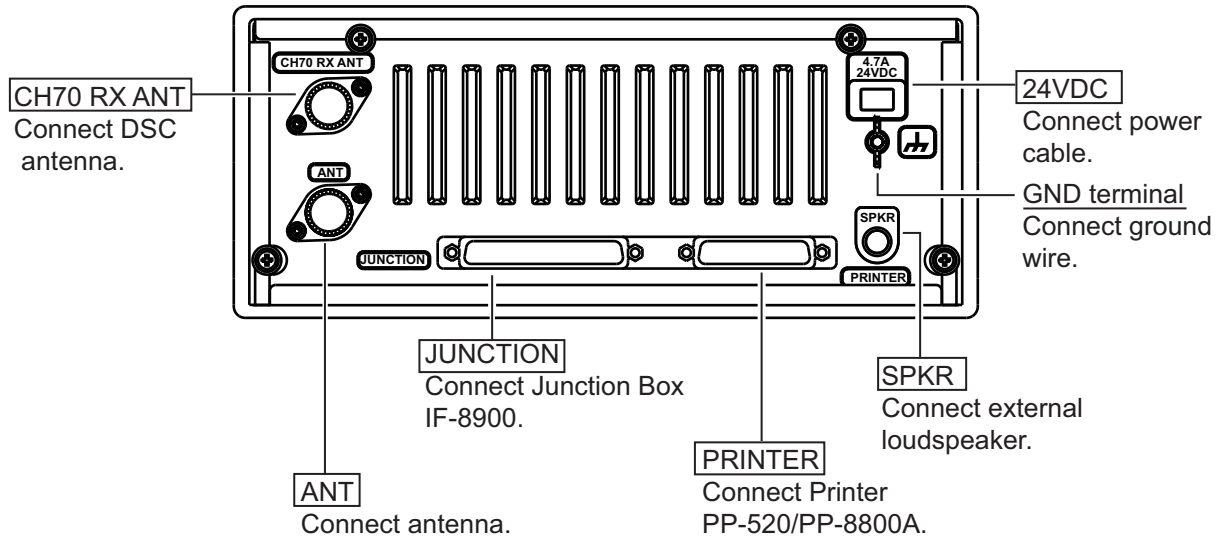

2.1 Power Supply

2.1.1 Solas Convention vessels, 100/220 VAC ship's mains

Solas Convention vessels must supply both AC and DC power to the transceiver unit, through an AC/DC power supply unit. The AC/DC Power Supply Unit PR-240 is optionally available. When the AC input fails, the DC power is activated.

Connect the reserve source of energy to the DC IN terminal on the PR-240. Connect the AC ship's mains to the AC IN terminal on the PR-240.

Be sure to ground the unit.

2.1.2 Radio battery

Attach the connector (supplied) to the power cable and connect the cable to the 24 VDC connector at the rear of the transceiver unit. Connect the wire ends to the radio battery line.

2.2 VHF Antenna

The VHF antenna is connected to the transceiver unit with a 50 ohm coaxial cable, type RG-10/U-Y. Make sure you leave some additional length in the cable for future service and maintenance.

Lay the coaxial cable and fasten an M-type plug to the cable (if necessary) as follows.

1. Remove the sheath by 35 mm.
2. Bare 23 mm of the center conductor. Trim the braided shield by 10 mm and tin.
3. Slide the coupling ring on the cable.
4. Screw the plug assembly on the cable.
5. Solder plug assembly to the braided shield through the solder holes. Solder the contact sleeve to the conductor.
6. Screw the coupling ring into the plug assembly.
7. Screw the plug into the ANT connector at the rear of the transceiver unit.

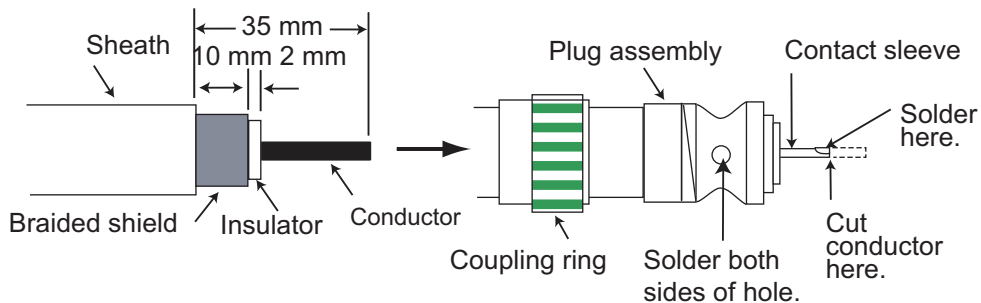

2.3 CH70 RX Antenna

The CH70 RX antenna is connected to the transceiver unit with a 50 ohm coaxial cable, type RG-10/U-Y. Attach an M-type plug to the cable (if necessary) as shown above. Screw the plug into the CH70 RX ANT connector at the rear of the transceiver unit.

2.4 Handset HS-2003

Connect the handset HS-2003 to the HANDSET connector on the front panel.

2.5 How to Ground the Transceiver Unit

Fasten a ground wire (local supply) between the GND terminal at the rear of the transceiver unit and ship's hull (or ground bus).

2.6 Junction Box

The junction box connects external equipment to the transceiver unit. The cable that connects between the junction box and the transceiver unit is pre-connected to the junction box. WAGO connectors connect the external equipment. A terminal opener is provided inside the junction box to open terminals on the connectors. See the illustration below for how to use the opener. Terminal lugs are provided to connect the shield of the TTYCSLA cables.

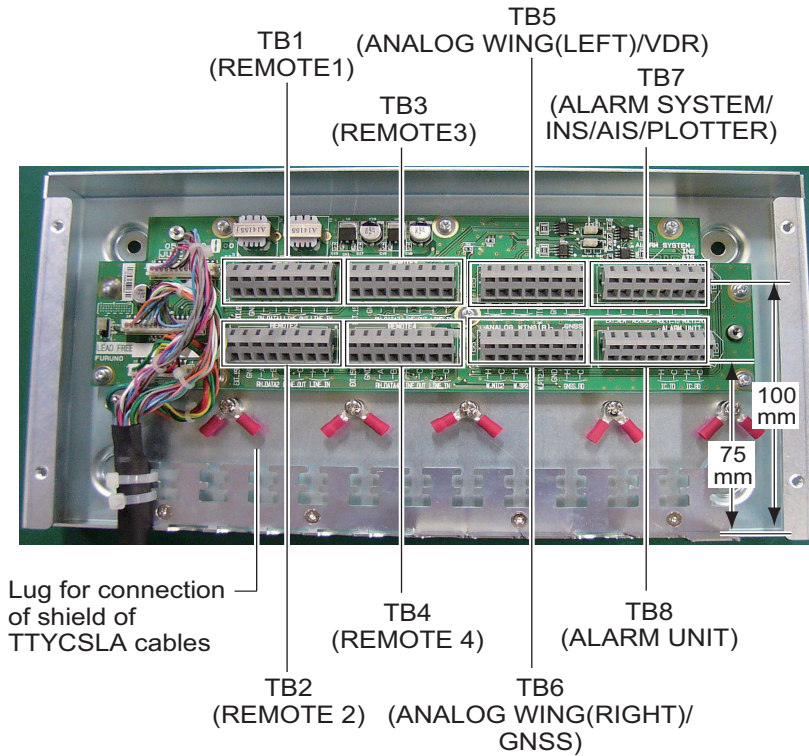

How to open WAGO connector

Procedure

1. Twist core.
2. Insert terminal opener and push.
3. Insert wire into hole. Be careful not to pinch sheath.
4. Release terminal opener.
5. Pull wire to confirm it is correctly inserted.

2.6.1 How to prepare the cables of external equipment

The cables shown are JIS (Japan Industry Standard) cables. See the Appendix for the equivalent cables.

Cable MPYC-4 (Alarm system)

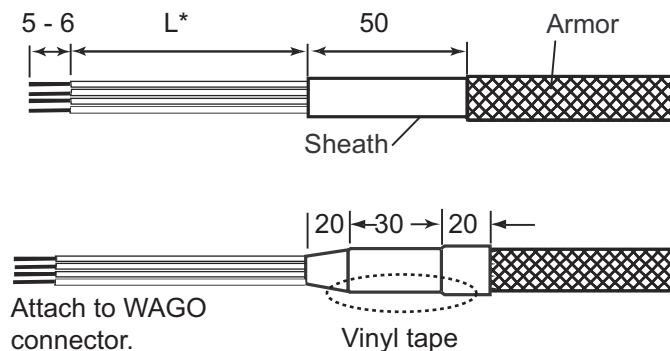

L*=Depends on location of connector. See illustration of junction box on page 9 for length.

Cable TTYCSLA-1 (NAV equipment)

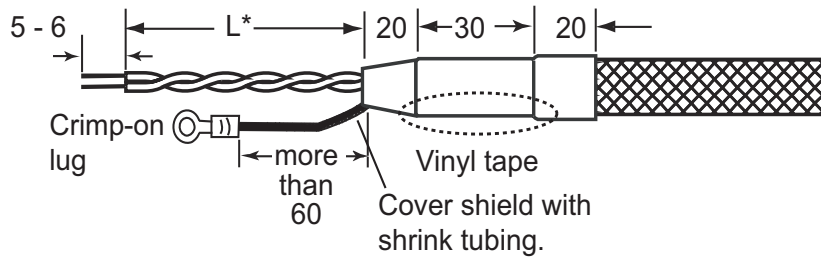

L*=Depends on location of connector. See illustration of junction box on page 9 for length.

Cable TTYCSLA-4 (Alarm Unit IC-350, INS, AIS, Plotter, MIC Receptacle Box, Remote Handset)

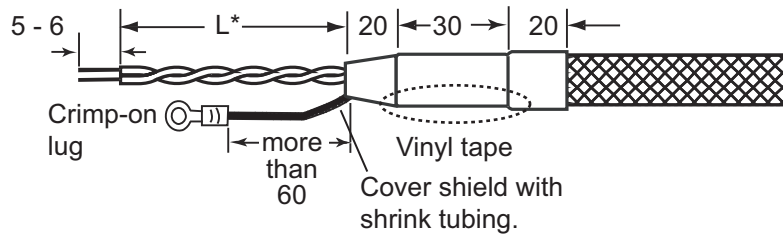

L*=Depends on location of connector. See illustration of junction box on page 9 for length.

2.6.2 Dummy plates in cable slots

Dummy plates are inserted at the factory in all but three cable slots. Remove or insert the dummy plates as necessary. Cover unused cable slots to comply to Ingress Protection Rating IP2x.

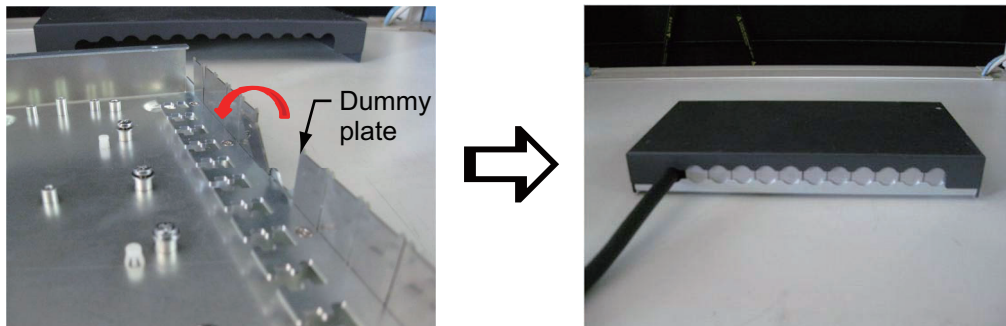

2. CONNECTIONS

2.6.3 How to fasten the cables to the Junction Box

Connect cables to related connectors. Fasten the cables to the cable posts with two cable ties.

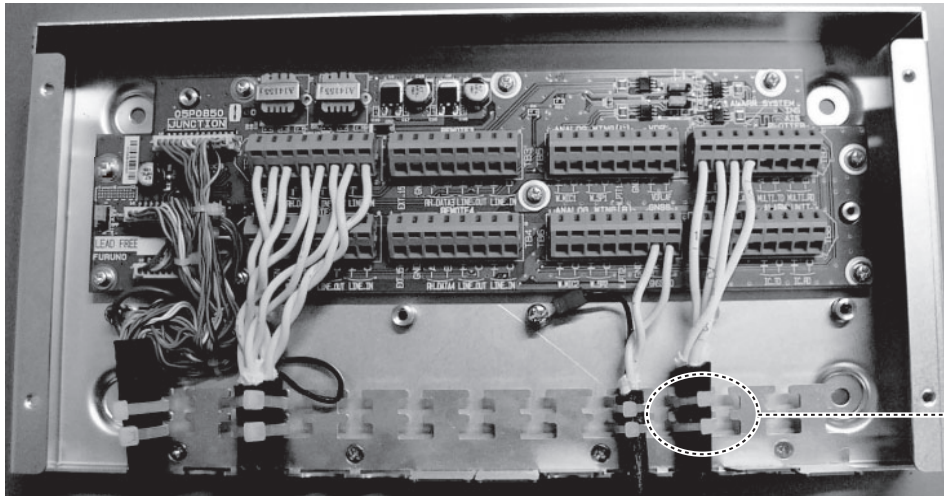

Fasten cable to post with two cable ties.

2.7 How to Connect the Remote Station without the Junction Box

The remote station (MIC receptacle box, etc.) can be connected directly to the transceiver unit, using the D-sub connector supplied as installation materials. Attach the connector to the cable as follows.

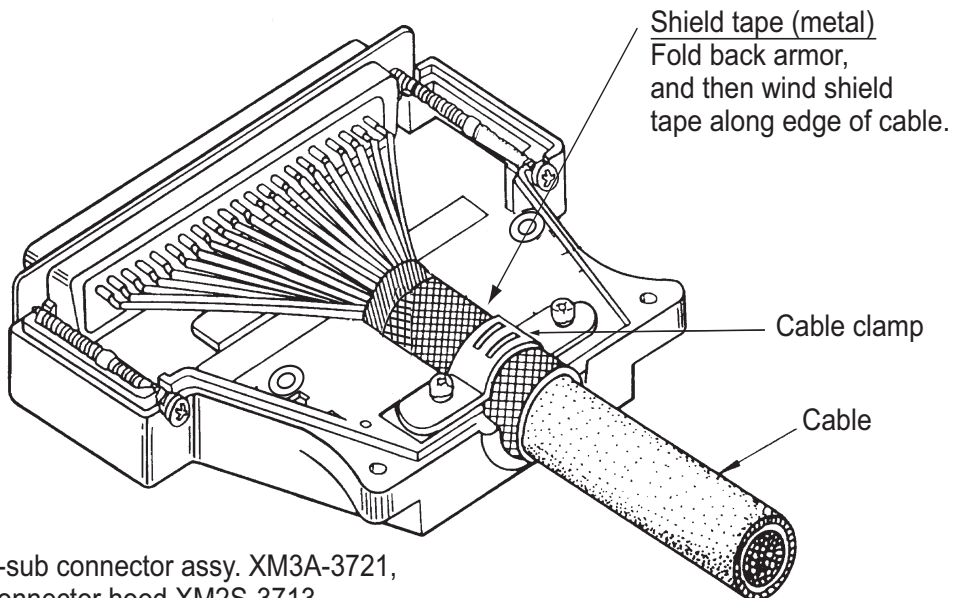

D-sub connector assy. XM3A-3721,
Connector hood XM2S-3713

2.8 AC/DC Power Supply Unit PR-240

The AC/DC Power Supply Unit PR-240 is shipped ready for connection to 200-230 VAC. For connection to 100 VAC-115 VAC, change the tap connection and terminal board connection as below. Attach applicable label (supplied in accessories) to the front panel according to the ship's mains.

Power	Tap connection	Terminal board	Label
200-230 VAC	SEL 230 V	(a) in figure below	200-230 VAC, 2.2-1.7 A, 1 ϕ , 50/60 Hz
100-115 VAC	SEL 115 V	(b) in figure below	100-115 VAC, 3.2-2.6 A, 1 ϕ , 50/60 Hz

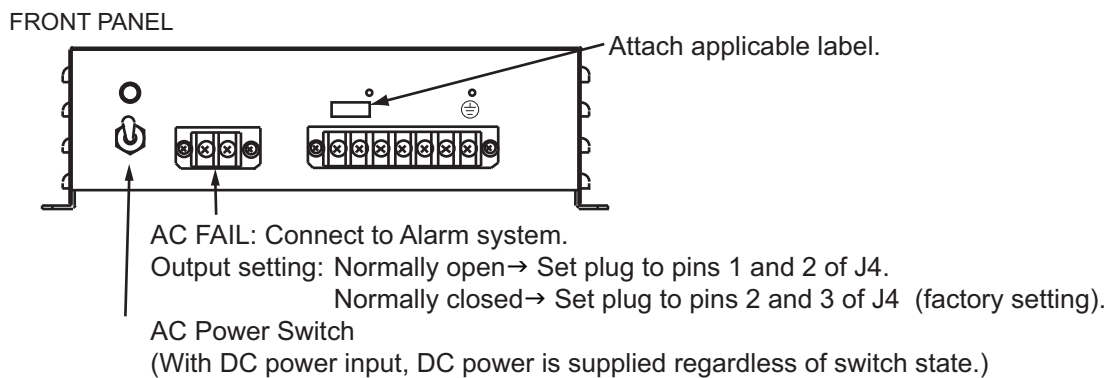
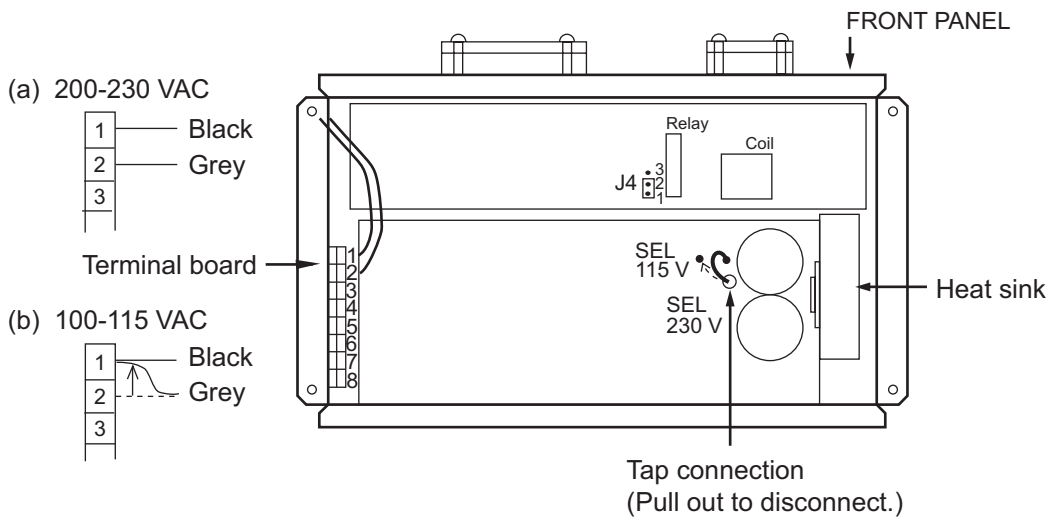
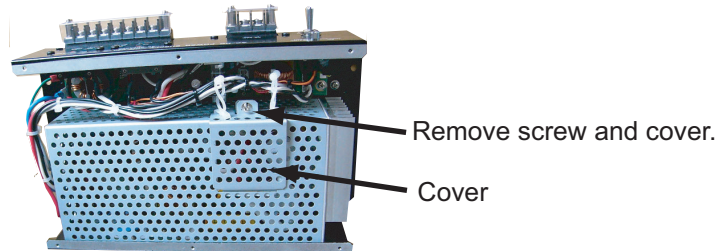

Protective earth

Connect a IV-2sq wire between the ship's ground and the ground terminal on the PR-240 to prevent electrical shock.

	CAUTION
	Attach protective earth securely to the ship's ground.
	The protective earth (grounding) is required to prevent electrical shock.

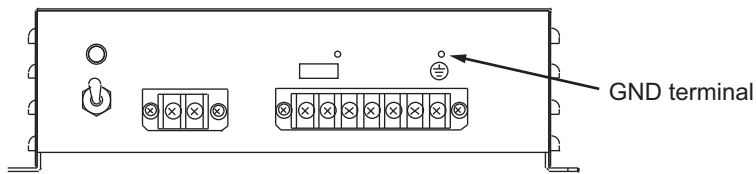

2.9 When the Handset HS-2003 is not Connected to the Transceiver Unit

When the Handset HS-2003 is not connected to the transceiver unit; namely, the remote handset is used always, turn on [M-HS HOOK] in the [OTHER] menu. See section 4.6.

2.10 Rainproof Cover for Transceiver Unit

The optional rainproof cover kit (Type: 05-104-2601, Code No. 001-174-310-10), consisting of a protective hood and double-sided tape, protects the connectors at the rear of the transceiver unit from rain and water splash. The cover can be used with both the desktop and flush mount installation methods. Connect the cables to the transceiver unit then install the cover as shown below.

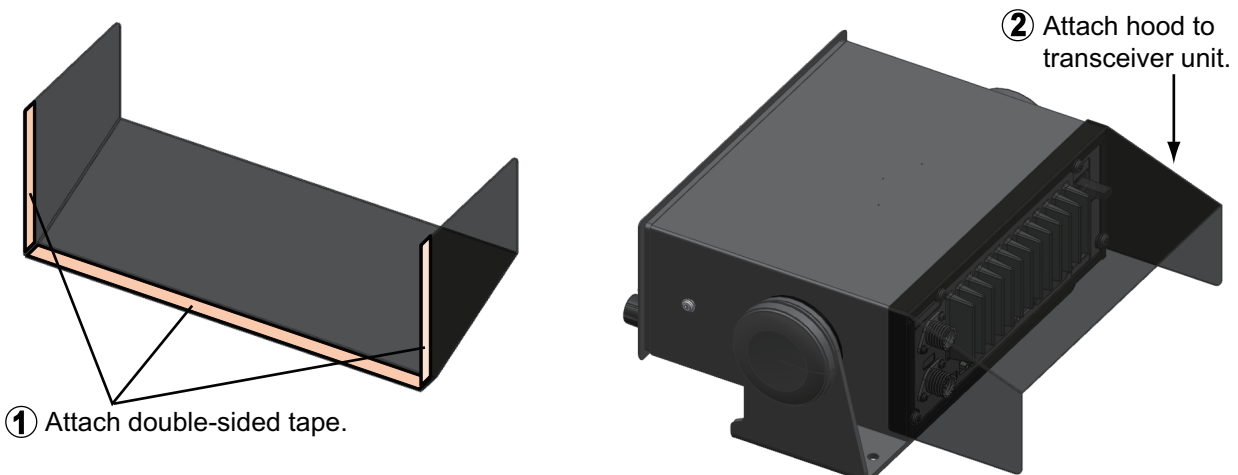

2.11 Jumper Setting for Termination

For termination on the remote stations, open the remote handset hanger as shown below. The default setting for J2 is "ON" (jumper block connected to pins 2 and 3). Confirm this setting. Re-connect the connector to the circuit board. Confirm that the plastic washers are in the screw holes in the handset hanger then close the hanger. Do this for all remote stations.

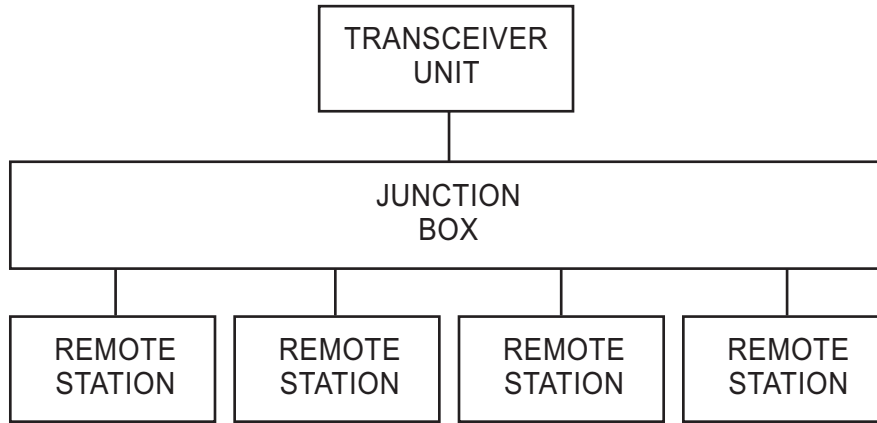

A maximum of four remote stations can be connected.

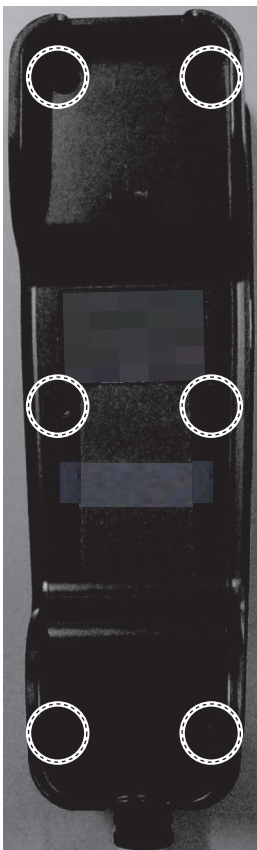

Unfasten six screws.

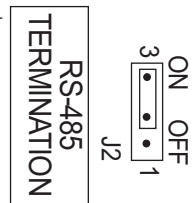
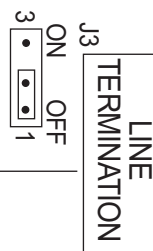
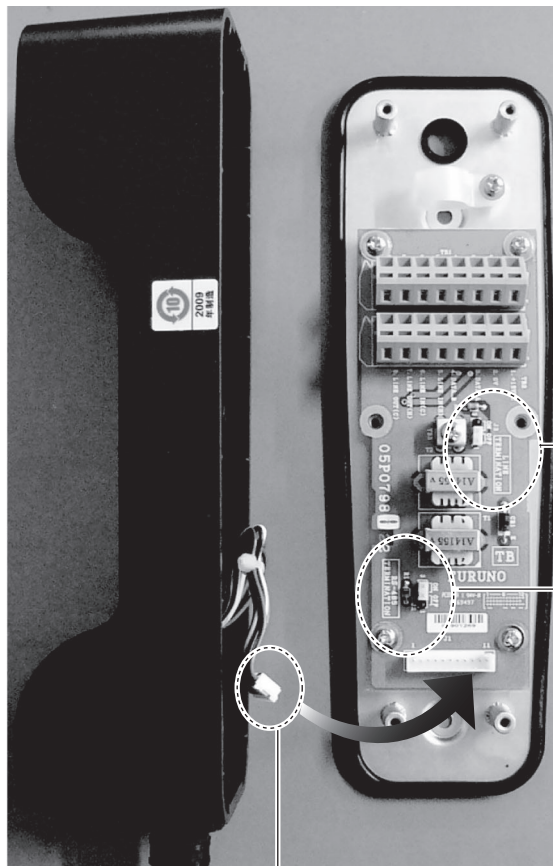

Short pins 2 and 3 for termination.

Disconnect connector from circuit board.

2.12 VHF Console

Install the VHF console following Chapter 3, then following the procedure in this section.

VHF console

1. Remove the cover assembly and printer assembly (or concealing lid) from the console. For the printer assembly, remove the cables connected to the transceiver unit and the terminal board.

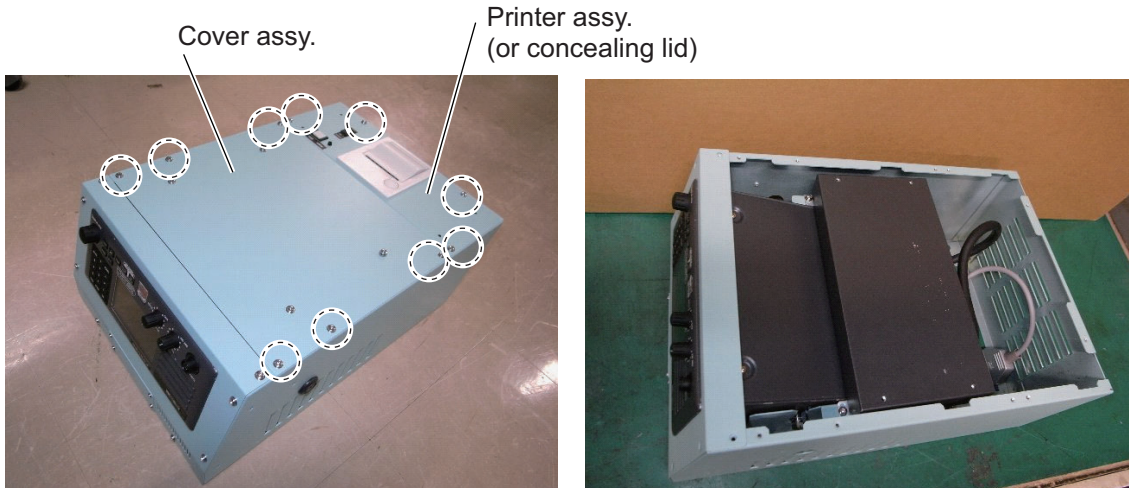

2. Connect the power cable from the power supply to the terminal board 1 (+) and 2 (-).

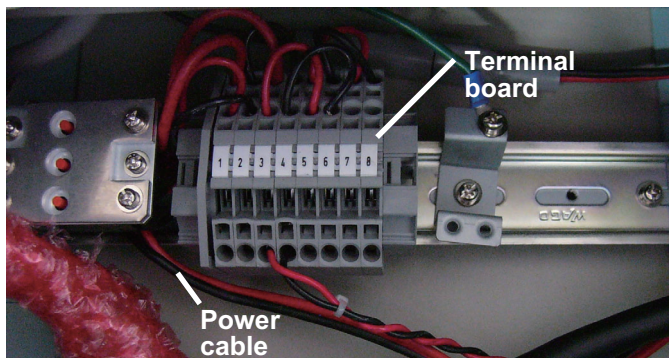

Terminal Board Connection

1. Process conductor

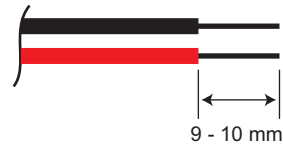

2. Wiring

- 1) Insert screwdriver (blade: 3.5x0.5 mm) to square hole.
- 2) Press screwdriver in direction of arrow to open spring in round hole.
- 3) Insert wire to round hole.
- 4) Remove screwdriver.

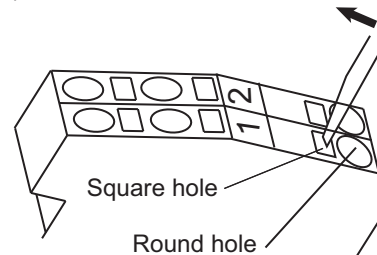

3. Connect the antenna coaxial cable as shown below.



GNSS cable

How to connect the coaxial cable:

1. Make a loop in the coaxial cable.
2. Fasten the coaxial cable to the GNSS cable with a cable tie.
3. Fasten the coaxial cable to the coaxial connector from the Junction Box.

4. Connect the ground wire from the ship to each ground terminal for the transceiver unit and the junction box.
5. Connect the cables from external equipment to the junction box and transceiver unit.
6. Fix the printer assembly (or concealing lid) and the cover assembly.

Emergency lamp

The emergency lamp can be installed on the left or right side (default arrangement) of the rack. For installation on the left side, unfasten the four screws from the front panel of the emergency lamp, rotate the emergency lamp 180° then refasten the screws.

1. Remove four screws from the right or left side of the rack.
2. Fasten the emergency lamp to the rack, with the four screws removed at step 1.
3. Insert the cable from the emergency lamp base into the cable entry of the rack. Connect the cable to the terminal board, referring to the interconnection diagram at the back of this manual.
4. Connect the emergency lamp connector to the emergency lamp.

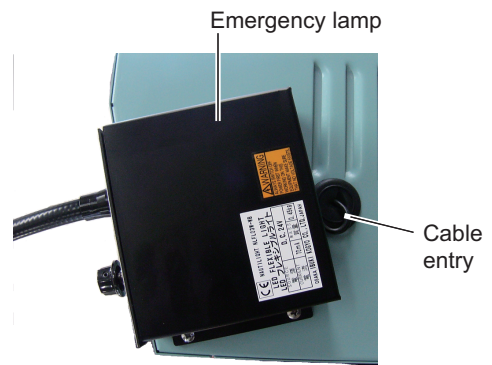

2.13 I/O Data

Data	Input/Output	Sentence, priority order
UAIS VHF Data-link Message	Input	VDM
Alert Acknowledge	Input	ACK
Alert State	Output	ALR
DSC information, Expanded DSC	Output	DSC, DSE
Equipment Information	Input/Output	PFEC
Position Info, Position Fix	Input	GNS>GGA>RMC>GLL
Target Latitude and Longitude	Output	TLL *
Time Info	Input	ZDA>RMC

* The TLL sentence can be output by selecting [TLL-S] on the [OTHER] menu of the [SERVICE] menu.

3. HOW TO ASSEMBLE THE VHF CONSOLE KIT

A VHF console kit is required to install the transceiver unit in the VHF console. There are two types of consoles, with a printer and without a printer.

1. Remove the cover assembly, the panel assembly and the printer assembly (or concealing lid) from the console. For the printer assembly, remove the cable connected to the terminal board.

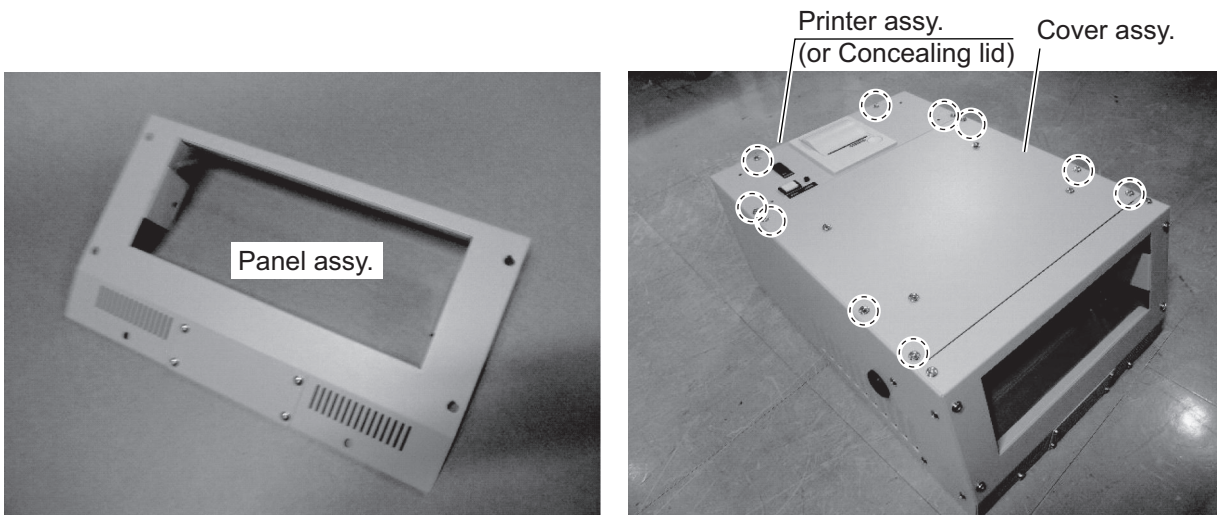

2. Fasten the panel assembly to the transceiver unit with the binding screws (use binding screws of the transceiver unit). Loosely insert M8×16 hex bolt (with plain washer) at both sides of the transceiver unit.

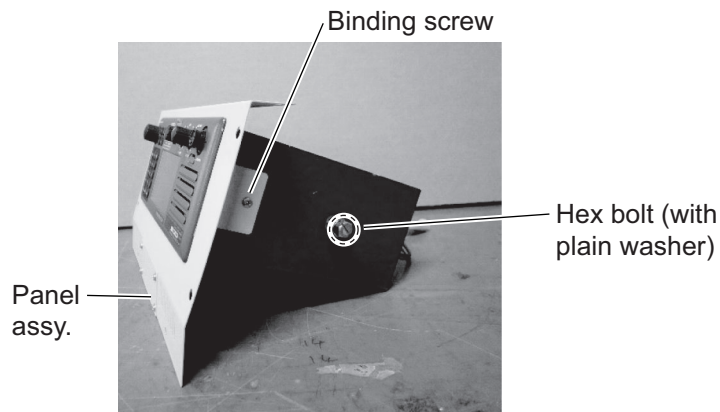

3. Set the transceiver unit to the console upside down. Fasten the transceiver unit to the rack case as shown below.

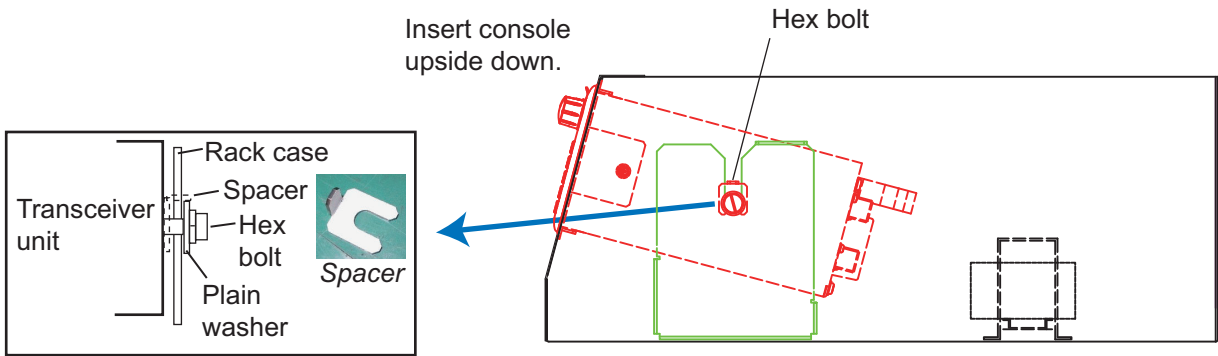

4. Replace the cable attached to the junction box with the cable (55 cm, 37-pin D-sub) supplied with the console kit. Connect the cable (37-pin D-sub) attached to the junction box to the transceiver unit.

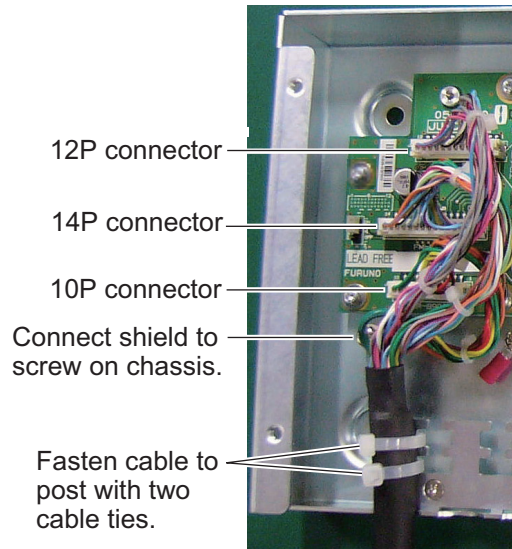

Replace original cable with cable assembly DSUB37M-PHX3-L550.

5. Fasten the junction box to the console and connect it to the transceiver unit.

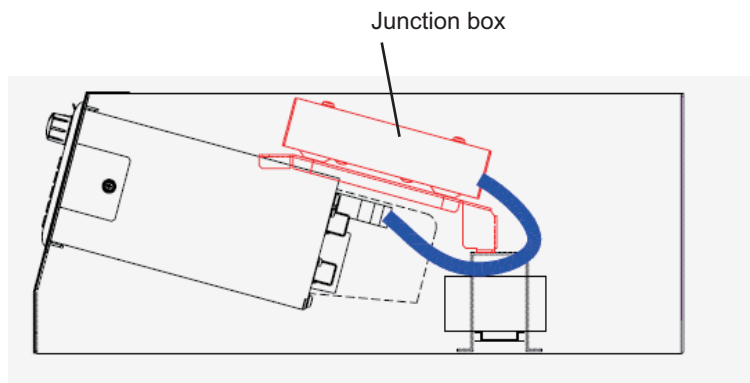

3. HOW TO ASSEMBLE THE VHF CONSOLE KIT

6. Connect the following to the transceiver unit:

- fuse to the power connector on the transceiver unit
- For the console with printer, connect the printer cable to the PRINTER port. (For no printer, fasten the concealing lid.)
- ground wire

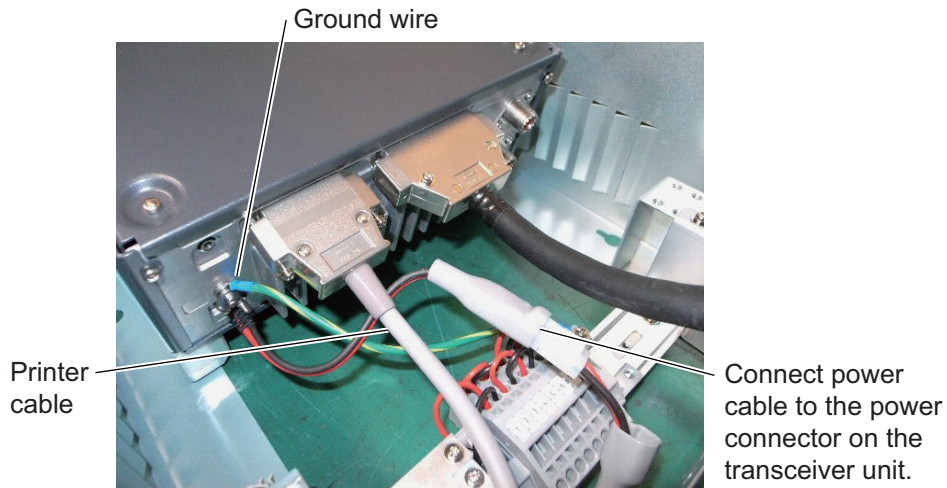

7. Fasten the cover assembly.

Note: If the console assembly is to be installed on the hull, see sections 1.11 and 2.12.

4. INITIAL SETTINGS

This chapter shows you how to enter the initial settings, which requires a password. Refer to FURUNO Information for the password. Entry of the MMSI and ATIS ID* numbers also requires a short inside the junction box or at the rear panel of the transceiver unit. Under no condition can the password or the location of the shorting points be released to the operator.

* ATIS is the acronym meaning Automatic Transmitter Identification System. ATIS is used on inland waterways in various countries in mainland Europe to identify ships. At the end of every transmission the radio sends a unique FFSK data signal that contains the user or ship's unique ATIS call sign. The FFSK signal identifies you to marine coast stations and inland stations.

4.1 How to Register the MMSI and ATIS ID

1. Do one of the procedures shown in the illustration below to enable the registering of the MMSI and ATIS ID numbers.

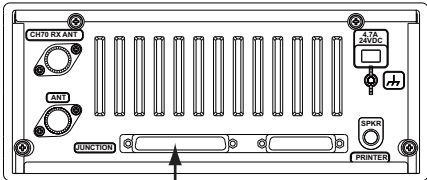
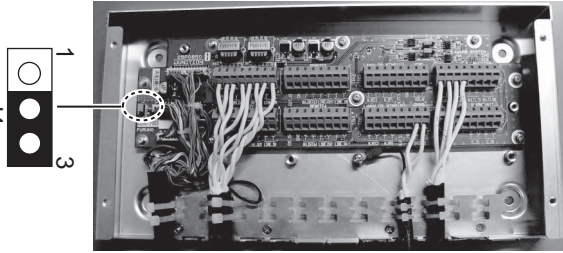
TRANSCEIVER UNIT	JUNCTION BOX
<p>Use a shorting link or the like to short pin 6 and 23 on the supplied D-SUB connector. Attach the connector to the JUNCTION connector (D-sub connector, 37 pin) at the rear of the transceiver unit.</p> 	<p>Open the junction box and set the jumper block J4 to pins 2 and 3 (OFF position) as shown below.</p>  <p>NOTICE: Jumper blocks J5 and J6 are for testing at the factory. Do not change the settings.</p>

2. Turn on the transceiver unit. The [INITIALIZE SETUP] menu appears, with the indication "HARDWARE KEY" and the "lock icon" shown.

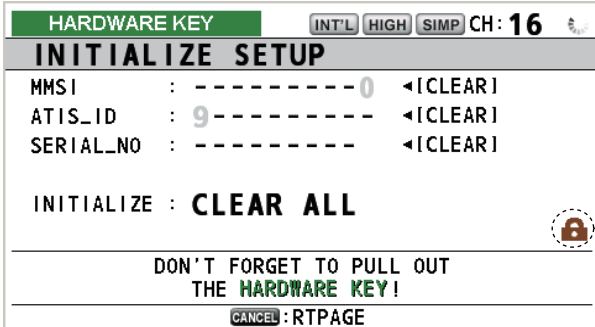

Lock icon (brown)

3. Enter the password. The lock icon turns green, the shackle of the lock opens and the cursor selects the MMSI. Push the **CH** knob to show the MMSI input box.



4. INITIAL SETTINGS

4. Use the numeric keys to enter the MMSI. Confirm the number then push the **CH** knob to submit the number.
5. **If applicable**, enter the ATIS ID like how you entered the MMSI.
Note: You can re-enter the MMSI/ATIS ID if it is wrong. Select the applicable **◀**[CLEAR] then push the **CH** knob. You are asked if it is OK to clear the number. Select [Yes] then push the **CH** knob. Select the number location then push the **CH** knob. Reenter the number.
6. Turn off the transceiver unit.
7. Do one of the following according to the action taken at step 1 to write the MMSI (and ATIS ID if applicable) to the memory.
Junction box: Restore the jumper block to its original position (connect jumper block to pins 1 and 2) and close the junction box.
Transceiver unit: Remove the connector.

Note: If you do not restore the jumper block to its original position or remove the shorting link, the message "HARDWARE KEY" appears at the top-left corner of the standby screen.

4.2 Service Menu

A password is required to open the [SERVICE] menu. Refer to the appropriate FURU-NO Information for how to open the [SERVICE] menu.

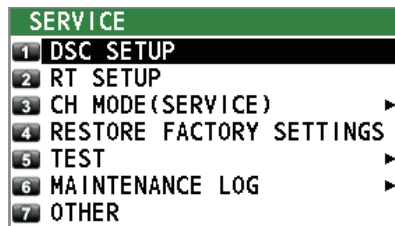

4.2.1 DSC SETUP menu

The [DSC SETUP] menu configures the radiotelephone's DSC section. Normally, adjustment of the items in this menu is not required. For information, see the Service Manual.

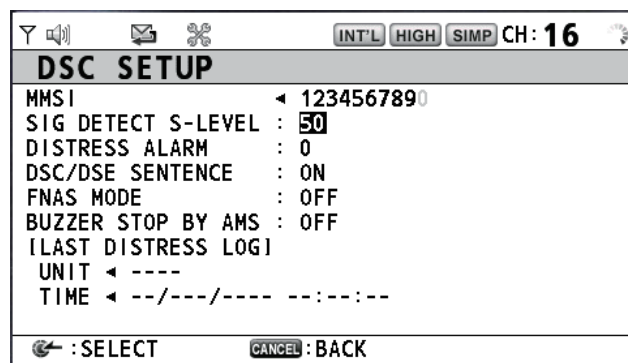

4.2.2 RT SETUP menu

The [RT SETUP] menu has the initial settings for the radiotelephone section. Normally, adjustment of the items in this menu is not required. For information, see the Service Manual.

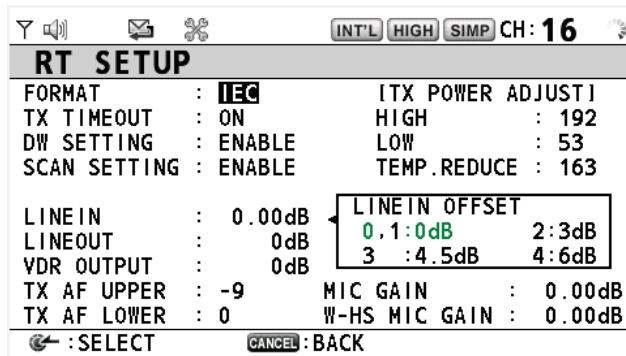

4.2.3 CH MODE (SERVICE) menu

The [CH MODE (SERVICE)] menu has the following sub-menus.



CH CONFIG

The [CH CONFIG] menu sets the TRX state, communication type and output power for every channel. Normally, adjustment of the items in this menu is not required. For information, see the Service Manual.

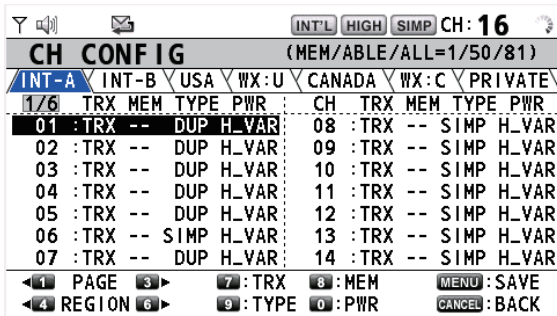

[--]	Channel not in use.
[RX]	Channel set to receive only.
[TRX]	Channel can send and receive.

CH TABLE

The CH TABLE menu sets the channel table for wireless communication. Normally, adjustment of the items in this menu is not required.



Note: When the setting for [CH TABLE] is changed, the channel configurations for [INT-A] and [INT-B] are reset to default settings.

4. INITIAL SETTINGS

REGION SETTINGS

The [REGION SETTINGS] menu sets the available regions in the [USER] menu. Regions which are disabled in the [REGION SETTINGS] menu will not be displayed in the [USER] menu. Set the available regions at installation.

REGION SETTINGS	
1 INT'L	: ENABLE
2 USA	: ENABLE
3 CANADA	: ENABLE
4 INLAND-W	: DISABLE
5 PRIVATE	: DISABLE

Note 1: [INLAND-W] option is not available if the ATIS-ID is not set.

Note 2: Regions already assigned in the [USER] menu cannot be disabled.

4.2.4 OTHER menu

OTHER	
DEMO MODE : OFF	RMS : OFF
P-BROWSER : OFF	
ROR MODE : OFF:RES	[for DEVELOP]
AMS MODE : LEGACY	POWER AMP : ON
AMS TALKER : 11	POPUP ALARM : ON
MULTI PORT : AIS/AMS	MIC L-BACK : OFF
TLL-S : OFF	R-HS UPDATE : ON
ALARM UNIT : DISCONNECT	DEBUG MODE : OFF
PRINTER : TYPE-A	CS SETTING : ENABLE
M-HS HOOK : ON	ATIS KILLER : INLAND-W
← : SELECT CANCEL : BACK	

[for DEVELOP]

The items in this column are for use by developers. Do not change the settings.

P-BROWSER: Activate or deactivate the parameter browser, which is controlled from a PC. For use by the service technician.

AMS MODE: [AMS MODE] selects whether an AMS (Alert Management System) is connected to this radio or not. AMS includes Bridge Alert Management System (BAMS).

There are three choices; [LEGACY], [AlertIF1] and [AlertIF2]. Select [Legacy] when this radio is not connected to an AMS.

[AlertIF1] uses the following input/output sentences: ALR/ACK.

[AlertIF2] uses the following input/output sentences: ALF, ALC, ARC, HBT, ACN for BAMS.

MULTI PORT: Select the equipment connected to the serial port. [AIS/AMS] (AIS transponder/AMS (Alert Management System)), [PLOTTER] (Navigational Plotter) or [INS] (Integrated Navigation System).

ALARM UNIT: Select [CONNECT] if the Alarm Unit IC-350 is connected to the radiotelephone.

PRINTER: Choose the printer model connected to the radiotelephone.

[TYPE-A]: PP-520

[TYPE-B]: PP-8800A

[OTHER]: Other printer

M-HS HOOK: Select where the main handset is connected. When the handset is not connected to the transceiver unit, and this setting is [NORMAL] (default setting), the system recognizes OFFHOOK state, preventing use of the remote station.

[NORMAL]: Select if the handset is connected to the transceiver unit.

[F(ON)]: The software forcibly sets ONHOOK state at the transceiver unit. Use this setting if the handset is not connected to the transceiver unit; namely, the remote handset is used always.

[F(OFF)]: The software forcibly sets OFFHOOK state.

4.3 Settings Inside the Transceiver Unit

Various jumper blocks are provided inside the transceiver unit to customize the system according to local regulations, user requirements, specifications, etc.

4.3.1 MIC type, MULTI SIO port receive format type, alarm output

Turn the transceiver unit upside down. Remove the cover to show the MAIN board (05P0843). Set the jumper blocks as required, referring to the illustration below. Jumper block information is also printed on the label on the inside cover.

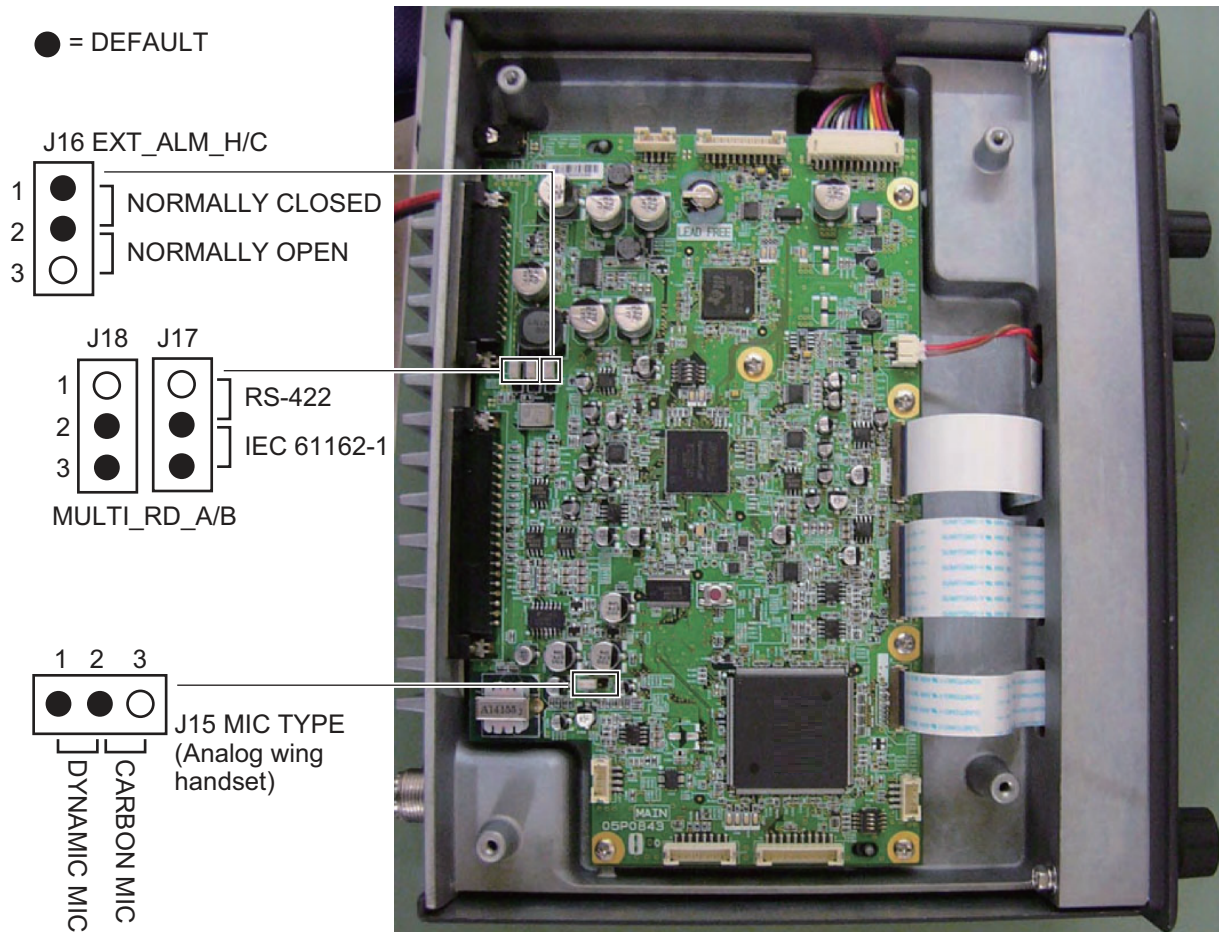

J15: Set the type of analog wing handset MIC used, carbon or dynamic.

J16: Define alarm output, normally closed or normally open.

J17, J18: Select the type of receiving circuit to use on the MULTI SIO port, RS-422 or IEC 61162-1 (Opt-Coupler). Set both jumpers to the same setting.

4. INITIAL SETTINGS

4.3.2 VHF antenna only

If a CH70 antenna is not installed, CH70 can be received with a VHF TX-RX antenna. Do the modification below to enable CH70 reception with a VHF TX-RX antenna. Note however that CH70 cannot be received during VHF transmission.

Remove the outer cover and the shield cover to show the TRX_WR Board (05P0841). Connect the supplied mini-pin assy. as shown below.

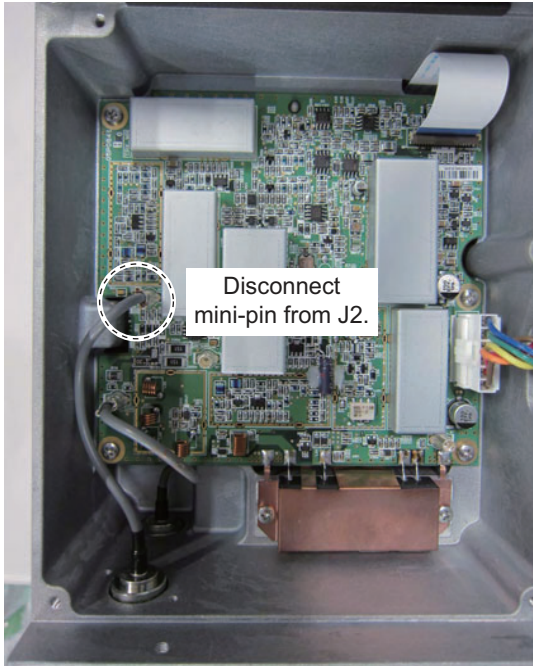

1. Disconnect the mini-pin from J2.

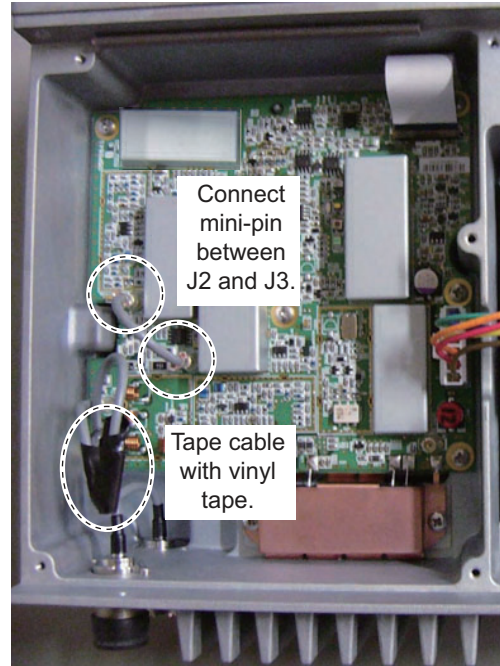

2. Connect the supplied mini-pin assy. between J2 and J3. Use vinyl tape to attach the cable disconnected at step 1 to the chassis or the W9 connector assy.

APPENDIX 1 JIS CABLE GUIDE

Cables listed in the manual are usually shown as Japanese Industrial Standard (JIS). Use the following guide to locate an equivalent cable locally.

JIS cable names may have up to 6 alphabetical characters, followed by a dash and a numerical value (example: DPYC-2.5). For core types D and T, the numerical designation indicates the *cross-sectional Area (mm²)* of the core wire(s) in the cable. For core types M and TT, the numerical designation indicates the *number of core wires* in the cable.

- | | | |
|--|-----------------------------|-----------------------|
| 1. Core Type | 2. Insulation Type | 3. Sheath Type |
| D Double core power line | P Ethylene Propylene Rubber | Y PVC (Vinyl) |
| T Triple core power line | | |
| M Multi core | | |
| TT Twisted pair communications (1Q=quad cable) | | |

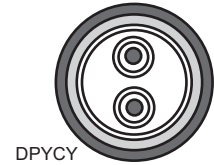

- | | | |
|----------------------|------------------------------|--|
| 4. Armor Type | 5. Sheath Type | 6. Shielding Type |
| C Steel | Y Anticorrosive vinyl sheath | SLA All cores in one shield, plastic tape w/aluminum tape |
| | | -SLA Individually shielded cores, plastic tape w/aluminum tape |

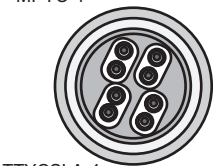
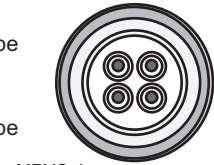

EX: ^{1 2 3 4 5 6} DPYCYSLA - 1.5 ^{1 2 3 4} MPYC - 4

Designation type Core Area (mm²) Designation type # of cores

The following reference table lists gives the measurements of JIS cables commonly used with Furuno products:

Type	Core		Cable Diameter	Type	Core		Cable Diameter
	Area	Diameter			Area	Diameter	
DPYC-1.5	1.5mm ²	1.56mm	11.7mm	TPYCY-1.5	1.5mm ²	1.56mm	14.5mm
DPYC-2.5	2.5mm ²	2.01mm	12.8mm	TPYCY-2.5	2.5mm ²	2.01mm	15.5mm
DPYC-4	4.0mm ²	2.55mm	13.9mm	TPYCY-4	4.0mm ²	2.55mm	16.9mm
DPYC-6	6.0mm ²	3.12mm	15.2mm	TPYCYSLA-1.5	1.5mm ²	1.56mm	13.9mm
DPYC-10	10.0mm ²	4.05mm	17.1mm	TTYC-7SLA	0.75mm ²	1.11mm	20.8mm
DPYC-16	16.0mm ²	5.10mm	19.4mm	TTYCSLA-1	0.75mm ²	1.11mm	9.4mm
DPYCY-1.5	1.5mm ²	1.56mm	13.7mm	TTYCSLA-1Q	0.75mm ²	1.11mm	10.8mm
DPYCY-2.5	2.5mm ²	2.01mm	14.8mm	TTYCSLA-4	0.75mm ²	1.11mm	15.7mm
DPYCY-4	4.0mm ²	2.55mm	15.9mm	TTYCY-4SLA	0.75mm ²	1.11mm	19.5mm
DPYCYSLA-1.5	1.5mm ²	1.56mm	11.9mm	TTYCYSLA-1	0.75mm ²	1.11mm	11.2mm
DPYCYSLA-2.5	2.5mm ²	2.01mm	13.0mm	TTYCYSLA-4	0.75mm ²	1.11mm	17.9mm
MPYC-2	1.0mm ²	1.29mm	10.0mm				
MPYC-4	1.0mm ²	1.29mm	11.2mm				
MPYC-7	1.0mm ²	1.29mm	13.2mm				
MPYCY-12	1.0mm ²	1.29mm	19.0mm				
MPYCY-19	1.0mm ²	1.29mm	22.0mm				

PACKING LIST



FM-8900S-A-J, FM-8900S-A-E, FM-8900S-A-E-HK

05EQ-X-9851-4

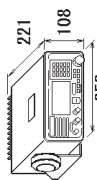
1/1

NAME	OUTLINE	DESCRIPTION/CODE No.	Q'TY
ユニット			
送受信機		FM-8900S-A	1
TRANSCEIVER UNIT		000-020-889-00 **	

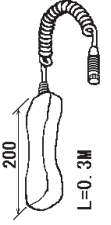
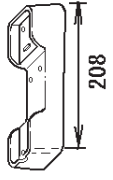
予備品		SPARE PARTS	
予備品		SP05-06201	1
SPARE PARTS		001-174-160-00	

付属品		ACCESSORIES	
ハンドセット		HS-2003-15	1
HANDSET		000-021-362-00	
ハンドセットハンガ-組品		FP05-05510	1
BRACKET FOR HANDSET		005-951-790-00	
付属品		FP05-05511	1
ACCESSORIES		005-951-920-00	

工事材料		INSTALLATION MATERIALS	
ケーブル(クミヒン)		LP-02-1(7A)-L3000	1
CABLE ASSEMBLY		000-176-274-11	

コード番号末尾の[**]は、選択品の代表コードを表します。
CODE NUMBER ENDING WITH "**" INDICATES THE CODE NUMBER OF REPRESENTATIVE MATERIAL.

NAME	OUTLINE	DESCRIPTION/CODE No.	Q'TY
工事材料		CP05-12601	1
INSTALLATION MATERIALS		001-174-170-00	

図書 DOCUMENT

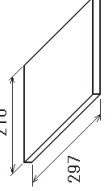
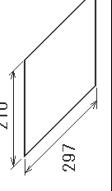
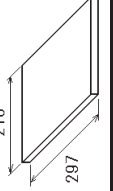
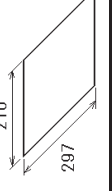
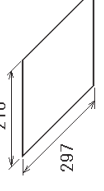
取扱説明書		OM*-56800-*	1
OPERATOR'S MANUAL		000-176-198-1*	**
操作要領書		OS*-56800-*	1
OPERATOR'S GUIDE		000-176-200-1*	**
装備要領書		IM*-56800-*	1
INSTALLATION MANUAL		000-176-202-1*	**
遭難警報ア- (VHF/MF)		*52-00101-*	1
DISTRESS ALERT CHART (VHF/MF)		000-809-269-1*	**
遭難通信要領		TIC-56800-*	1
PROCEDURE FOR DISTRESS VHF		000-176-225-1*	

型式/コード番号が2段の場合、下段より上段に代わる過渡期品であり、どちらかが入っています。なお、品質は変わりません。
TWO TYPES AND CODES MAY BE LISTED FOR AN ITEM. THE LOWER PRODUCT MAY BE SHIPPED IN PLACE OF THE UPPER PRODUCT. QUALITY IS THE SAME.





(略図の寸法は、参考値です。DIMENSIONS IN DRAWING FOR REFERENCE ONLY.)

PACKING LIST

FM-8900S-A-J-V, FM-8900S-A-E-V, FM-8900S-A-J-V-HK, FM-8900S-A-E-V, FM-8900S-A-E-V-HK

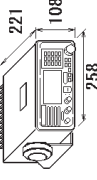
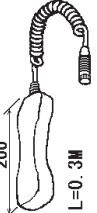
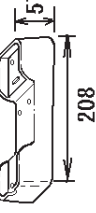
05EQ-X-9852-4





1/1

NAME	OUTLINE	DESCRIPTION/CODE No.	Q'TY
ユニット			
送受信機		FM-8900S-A	1
TRANSCEIVER UNIT		000-020-889-00	**
付属品	ACCESSORIES	FP05-05730	
ハンドセット		HS-2003-15	1
HANDSET		000-021-362-00	
ハンドセットハンガ-組品		FP05-05510	1
BRACKET FOR HANDSET		005-951-790-00	
付属品		FP05-05511	1
ACCESSORIES		005-951-920-00	
工事材料	INSTALLATION MATERIALS	CP05-12600	
ケーブル(クミヒン)		LP-02-1(7A)-L3000	1
CABLE ASSEMBLY		000-176-274-11	
工事材料		CP05-12601	1
INSTALLATION MATERIALS		001-174-170-00	
図書	DOCUMENT		
取扱説明書		OM*-56800-*	1
OPERATOR'S MANUAL		000-176-198-1*	**

コード番号末尾の[**]は、選択品の代表コードを表します。

CODE NUMBER ENDING WITH "**" INDICATES THE CODE NUMBER OF REPRESENTATIVE MATERIAL.

(略図の寸法は、参考値です。DIMENSIONS IN DRAWING FOR REFERENCE ONLY.)

NAME	OUTLINE	DESCRIPTION/CODE No.	Q'TY
操作要領書		OS*-56800-*	1
OPERATOR'S GUIDE		000-176-200-1*	**
装備要領書		IM*-56800-*	1
INSTALLATION MANUAL		000-176-202-1*	**
遭難警報プロ-(VHF/MF)		*52-00101-*	1
DISTRESS ALERT CHART (VHF/MF)		000-809-269-1*	**
遭難通信要領		TIC-56800-*	1
PROCEDURE FOR DISTRESS VHF		000-176-225-1*	

型式/コード番号が2段の場合、下段より上段に代わる通達期品であり、どちらかが入っています。なお、品質は変わりません。

TWO TYPES AND CODES MAY BE LISTED FOR AN ITEM. THE LOWER PRODUCT MAY BE SHIPPED IN PLACE OF THE UPPER PRODUCT. QUALITY IS THE SAME.

C5680-Z02-E

PACKING LIST

FM-8900S-N-J-V, FM-8900S-N-E-V, FM-8900S-N-J-V-HK, FM-8900S-N-E-V, FM-8900S-N-E-V-HK

05EQ-X-9865-3

1/1

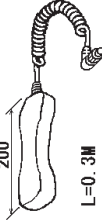
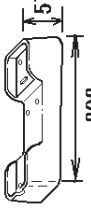
NAME	OUTLINE	DESCRIPTION/CODE No.	Q'TY
ユニット			
送受信機		FM-8900S-N	1
付属品	ACCESSORIES	000-020-920-00 FP05-05720	**
ハンドセット		HS-2003-15-L 000-021-364-00	1
ハンドセットハンガ-組品		FP05-05510 005-951-790-00	1
付属品		FP05-05511 005-951-920-00	1
ACCESSORIES			



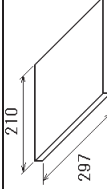

NAME	OUTLINE	DESCRIPTION/CODE No.	Q'TY
工事材料	INSTALLATION MATERIALS		
ケーブル(ケミヒン)		LP-02-1(7A)-L3000 000-176-274-11	1
工事材料		CP05-12601 001-174-170-00	1
INSTALLATION MATERIALS			

NAME	OUTLINE	DESCRIPTION/CODE No.	Q'TY
図書	DOCUMENT		
取扱説明書		OM*-56800-* 000-176-198-1*	1
OPERATOR'S MANUAL			

コード番号末尾の[**]は、選択品の代表コードを表します。

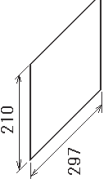
CODE NUMBER ENDING WITH "**" INDICATES THE CODE NUMBER OF REPRESENTATIVE MATERIAL

(略図の寸法は、参考値です。DIMENSIONS IN DRAWING FOR REFERENCE ONLY.)

NAME	OUTLINE	DESCRIPTION/CODE No.	Q'TY
操作要領書		OS*-56800-*	1
OPERATOR'S GUIDE			
装備要領書		IM*-56800-*	1
INSTALLATION MANUAL			
遭難警報ワ- (VHF/MF)		000-176-202-1*	1
DISTRESS ALERT CHART (VHF/MF)		*52-00101-*	1
遭難通信要領		000-809-269-1*	1
PROCEDURE FOR DISTRESS VHF		TIC-56800-*	1
		000-176-225-1*	

型式/コード番号が2段の場合、下段より上段に代わる過渡期品であり、どちらかが入っています。なお、品質は変わりません。

TWO TYPES AND CODES MAY BE LISTED FOR AN ITEM. THE LOWER PRODUCT MAY BE SHIPPED IN PLACE OF THE UPPER PRODUCT. QUALITY IS THE SAME.

PACKING LIST

HS-8900-15/20, HS-8900-W-15

05EQ-X-9856 -0 1/1
A-4

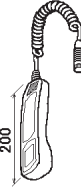
NAME	UNIT	OUTLINE	DESCRIPTION/CODE No.	Q'TY
ユニット リモートセット REMOTE HANDSET		 200	HS-8900-* 000-020-880-00 **	1

コード番号末尾の[**]は、選択品の代表コードを表します。

CODE NUMBER ENDING WITH "**" INDICATES THE CODE NUMBER OF REPRESENTATIVE MATERIAL.

型式/コード番号が2段の場合、下段より上段に代わる過渡期品であり、どちらが入っています。なお、品質は変わりません。

TWO TYPES AND CODES MAY BE LISTED FOR AN ITEM. THE LOWER PRODUCT MAY BE SHIPPED IN PLACE OF THE UPPER PRODUCT. QUALITY IS THE SAME.

(略図の寸法は、参考値です。DIMENSIONS IN DRAWING FOR REFERENCE ONLY.)

C5680-Z05-A

PACKING LIST

HG-8900/-W

05EQ-X-9857 -0 1/1
A-5

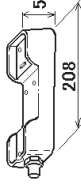
NAME	UNIT	OUTLINE	DESCRIPTION/CODE No.	Q'TY
ユニット ハンドセット HANDSET HANGER		 208 57	HG-8900* 000-020-882-00 **	1

コード番号末尾の[**]は、選択品の代表コードを表します。

CODE NUMBER ENDING WITH "**" INDICATES THE CODE NUMBER OF REPRESENTATIVE MATERIAL.

型式/コード番号が2段の場合、下段より上段に代わる過渡期品であり、どちらが入っています。なお、品質は変わりません。

TWO TYPES AND CODES MAY BE LISTED FOR AN ITEM. THE LOWER PRODUCT MAY BE SHIPPED IN PLACE OF THE UPPER PRODUCT. QUALITY IS THE SAME.



(略図の寸法は、参考値です。DIMENSIONS IN DRAWING FOR REFERENCE ONLY.)

C5680-Z06-A

PACKING LIST

05EQ-X-9854 -0 1/1
A-6

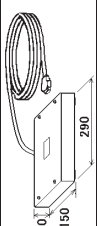
IF-8900

NAME	OUTLINE	DESCRIPTION/CODE No.	QTY
ユニット 接続箱 JUNCTION BOX		IF-8900 000-020-877-00	1
工事材料 INSTALLATION MATERIALS		CP05-12701 001-174-210-00	1



型式/コード番号が2段の場合、下段より上段に代わる過渡期品であり、どちらが入っています。なお、品質は変わりません。
TWO TYPES AND CODES MAY BE LISTED FOR AN ITEM. THE LOWER PRODUCT MAY BE SHIPPED IN PLACE OF THE UPPER PRODUCT. QUALITY IS THE SAME.
(略図の寸法は、参考値です。 DIMENSIONS IN DRAWING FOR REFERENCE ONLY.)

C5680-Z03-A

PACKING LIST

05EQ-X-9855 -0 1/1
A-7

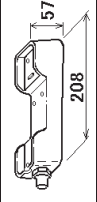
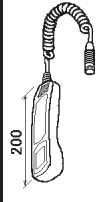
RB-8900-15/20, RB-8900-W-15



NAME	OUTLINE	DESCRIPTION/CODE No.	QTY
ユニット ハンドセットホルガ - HANDSET HANGER		HG-8900* 000-020-882-00 **	1
リモートハンドセット REMOTE HANDSET		HS-8900-* 000-020-880-00 **	1
工事材料 INSTALLATION MATERIALS		CP05-12801 001-174-260-00	1

コード番号末尾の[*]**は、選択品の代表コードを表します。
CODE NUMBER ENDING WITH ".*" INDICATES THE CODE NUMBER OF REPRESENTATIVE MATERIAL

型式/コード番号が2段の場合、下段より上段に代わる過渡期品であり、どちらが入っています。なお、品質は変わりません。
TWO TYPES AND CODES MAY BE LISTED FOR AN ITEM. THE LOWER PRODUCT MAY BE SHIPPED IN PLACE OF THE UPPER PRODUCT. QUALITY IS THE SAME.
(略図の寸法は、参考値です。 DIMENSIONS IN DRAWING FOR REFERENCE ONLY.)

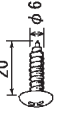

C5680-Z04-A

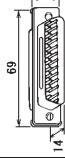
CODE NO.	001-199-600-00	05EQ-X-9407-1
TYPE	CP05-12601	1/1

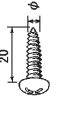

工事材料表		INSTALLATION MATERIALS			
番号	名称	略図	型名/規格	数量	用途/備考
NO.	NAME	OUTLINE	DESCRIPTIONS	QTY	REMARKS
1	+1578791'・1/2 SELF-TAPPING SCREW		6X20 SUS304 CODE NO. 000-162-613-10	4	
2	ミニピンアッシー(1) MINI PIN ASSY(1)		L-70 CODE NO. 000-165-834-10	1	
3	コネクタフード (XMZ) CONNECTOR HOOD		XMZS-3713 CODE NO. 000-176-092-10	1	
4	コネクタ (XM3) CONNECTOR		XM3A-3721 CODE NO. 000-176-295-10	1	

型式/コード番号が2段の場合、下段より上段に代わる選装部品であり、どちらかが入っています。なお、品質は変わりません。
TWO TYPES AND CODES MAY BE LISTED FOR AN ITEM. THE LOWER PRODUCT MAY BE SHIPPED IN PLACE OF THE UPPER PRODUCT.
QUALITY IS THE SAME.
(附図の寸法は、参考値です。 DIMENSIONS IN DRAWING FOR REFERENCE ONLY.)

CODE NO.	001-174-210-00	05EQ-X-9402-0
TYPE	CP05-12701	1/1

工事材料表		INSTALLATION MATERIALS			
番号	名称	略図	型名/規格	数量	用途/備考
NO.	NAME	OUTLINE	DESCRIPTIONS	QTY	REMARKS
1	+1578791'・1/2 SELF-TAPPING SCREW		5X20 SUS304 CODE NO. 000-162-608-10	4	
2	ケーブルタイ CABLE TIE		CY-150N CODE NO. 000-162-186-10	22	

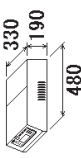
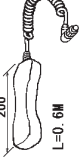
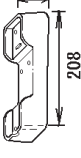
型式/コード番号が2段の場合、下段より上段に代わる選装部品であり、どちらかが入っています。なお、品質は変わりません。
TWO TYPES AND CODES MAY BE LISTED FOR AN ITEM. THE LOWER PRODUCT MAY BE SHIPPED IN PLACE OF THE UPPER PRODUCT.
QUALITY IS THE SAME.
(附図の寸法は、参考値です。 DIMENSIONS IN DRAWING FOR REFERENCE ONLY.)

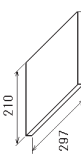
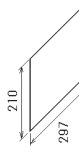
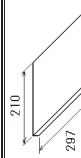
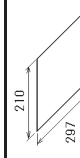
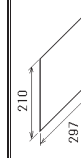
NAME	UNIT	OUTLINE	DESCRIPTION/CODE No.	QTY
ユニット				
VHFコントロール			RC-8900-SN-*	1
VHF CONSOLE			000-022-191-00 **	
付属品 ACCESSORIES				
ハンドセット			HS-2003-20-L	1
HANDSET			000-021-366-00	
ハンドセット用カギ組品			FP05-05510	1
BRACKET FOR HANDSET			005-951-790-00	
工事材料 INSTALLATION MATERIALS				
工事材料			CP05-13101	1
INSTALLATION MATERIALS			001-197-090-00	
図書 DOCUMENT				
取扱説明書			OM*-56800-*	1
OPERATOR'S MANUAL			000-176-198-1*	
操作要領書			OS*-56800-*	1
OPERATOR'S GUIDE			000-176-200-1*	
整備要領書			IM*-56800-*	1
INSTALLATION MANUAL			000-176-202-1*	
運難警報7カ- (VHF/MF)			*52-00101-*	1
DISTRESS ALERT CHART (VHF/MF)			000-809-269-1*	
運難通信要領			TIC-56800-*	1
PROCEDURE FOR DISTRESS VHF			000-176-225-1*	

コード番号末尾の[*]**は、選択品の代表コードを表します。
 CODE NUMBER ENDING WITH "*"** INDICATES THE CODE NUMBER OF REPRESENTATIVE MATERIAL.



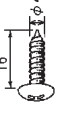
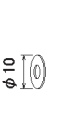



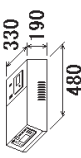
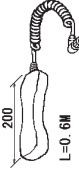
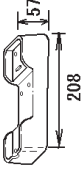

型式/コード番号が2段階の場合、下段より上段に代わる過渡期品であり、どちらかが入っています。なお、品質は変わりません。
 TWO TYPES AND CODES MAY BE LISTED FOR AN ITEM. THE LOWER PRODUCT MAY BE SHIPPED IN PLACE OF THE UPPER PRODUCT. QUALITY IS THE SAME.
 (略図の寸法は、参考値です。 DIMENSIONS IN DRAWING FOR REFERENCE ONLY.)

CODE NO.		05EQ-X-9403-0		1/1	
TYPE		CP05-12801			
工事材料表					
INSTALLATION MATERIALS					
番号	名称	略図	型名/規格	数量	用途/備考
NO.	NAME	OUTLINE	DESCRIPTIONS	QTY	REMARKS
1	セルフタッピングネジ		4X16 SUS304 CODE NO. 000-162-605-10	2	
2	ワッシャー		M4 CODE NO. 000-166-234-10	2	

型式/コード番号が2段階の場合、下段より上段に代わる過渡期品であり、どちらかが入っています。なお、品質は変わりません。
 TWO TYPES AND CODES MAY BE LISTED FOR AN ITEM. THE LOWER PRODUCT MAY BE SHIPPED IN PLACE OF THE UPPER PRODUCT.
 QUALITY IS THE SAME.
 (略図の寸法は、参考値です。 DIMENSIONS IN DRAWING FOR REFERENCE ONLY.)

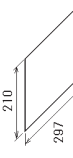
PACKING LIST

RC-8900-SA-*, RC-8900-SA-*/HK A-13

NAME	OUTLINE	DESCRIPTION/CODE No.	QTY
ユニット			
VHFコンソール		RC-8900-SA-*	1
VHF CONSOLE		000-022-194-00 **	
付属品			
ハンドセット		HS-2003-20-L	1
HANDSET		000-021-366-00	
ハンドセット用組品		FP05-05510	1
BRACKET FOR HANDSET		005-951-790-00	
感熱記録紙		TP058-30CL	1
RECORDING PAPER		000-154-047-11	
工事材料			
INSTALLATION MATERIALS			
工事材料		CP05-13101	1
INSTALLATION MATERIALS		001-197-090-00	
図書			
DOCUMENT			
取扱説明書		OM*-56800-*	1
OPERATOR'S MANUAL		000-176-198-1*	
操作要領書		OS*-56800-*	1
OPERATOR'S GUIDE		000-176-200-1*	
整備要領書		IM*-56800-*	1
INSTALLATION MANUAL		000-176-202-1*	
運難警報70-(VHF/MF)		*52-00101-*	1
DISTRESS ALERT CHART (VHF/MF)		000-809-269-1*	
運難通信要領		TIC-56800-*	1
PROCEDURE FOR DISTRESS VHF		000-176-225-1*	

コード番号末尾の[*]は、選択品の代表コードを表します。





CODE NUMBER ENDING WITH "*" INDICATES THE CODE NUMBER OF REPRESENTATIVE MATERIAL

型式/コード番号が2段階の場合、下段より上段に代わる過渡用品であり、どちらかが入っています。なお、品質は変わりません。
TWO TYPES AND CODES MAY BE LISTED FOR AN ITEM. THE LOWER PRODUCT MAY BE SHIPPED IN PLACE OF THE UPPER PRODUCT. QUALITY IS THE SAME.

(略図の寸法は、参考値です。DIMENSIONS IN DRAWING FOR REFERENCE ONLY.)

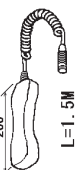
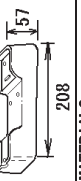
PACKING LIST

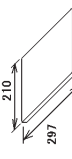
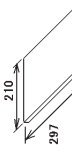
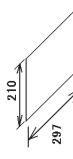
RC-8800-*/A-*/HK A-12

NAME	OUTLINE	DESCRIPTION/CODE No.	QTY
ユニット			
VHFコンソール		RC-8800-*/A	1
VHF CONSOLE		000-054-240-00 **	
付属品			
ハンドセット		HS-2003-15	1
HANDSET		000-015-996-00	
ハンドセット用組品		FP05-05510	1
BRACKET FOR HANDSET		005-951-790-00	
工事材料			
INSTALLATION MATERIALS			
工事材料		CP05-10201	1
INSTALLATION MATERIALS		005-371-850-00	
図書			
DOCUMENT			
取扱説明書		OM*-56420-*	1
OPERATOR'S MANUAL		000-149-929-1*	
操作要領書		OS*-56420-*	1
OPERATOR'S GUIDE		000-149-933-1*	
整備要領書		IM*-56420-*	1
INSTALLATION MANUAL		000-149-931-1*	
運難警報70-(VHF/MF)		*52-00101-*	1
VHF/MF DISTRESS ALERT FLOW		000-809-269-1*	
運難通信要領書(和/英)		TIC-56420-*	1
DISTRESS PROCEDURE		000-149-935-1*	

コード番号末尾の[*]は、選択品の代表コードを表します。

CODE NUMBER ENDING WITH "*" INDICATES THE CODE NUMBER OF REPRESENTATIVE MATERIAL

型式/コード番号が2段階の場合、下段より上段に代わる過渡用品であり、どちらかが入っています。なお、品質は変わりません。
TWO TYPES AND CODES MAY BE LISTED FOR AN ITEM. THE LOWER PRODUCT MAY BE SHIPPED IN PLACE OF THE UPPER PRODUCT. QUALITY IS THE SAME.

(略図の寸法は、参考値です。DIMENSIONS IN DRAWING FOR REFERENCE ONLY.)



表1 TABLE 1

寸法区分 (mm) DIMENSION	公差 (mm) TOLERANCE
L ≤ 50	±1.5
50 < L ≤ 100	±2.5
100 < L ≤ 500	±3

注記

- 1) 指定外の寸法公差は表1による。
- 2) #印寸法は最小サービスマン寸法とする。
- 3) 取付用ネジは+トラスチックピンネジ6×2.0を使用のこと。

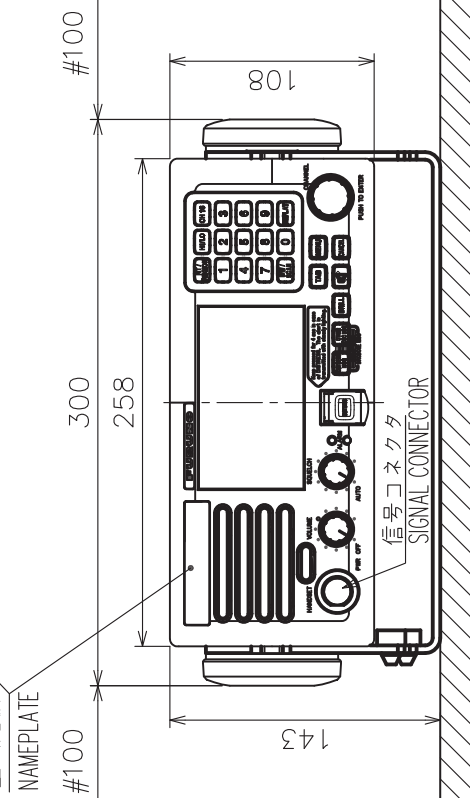
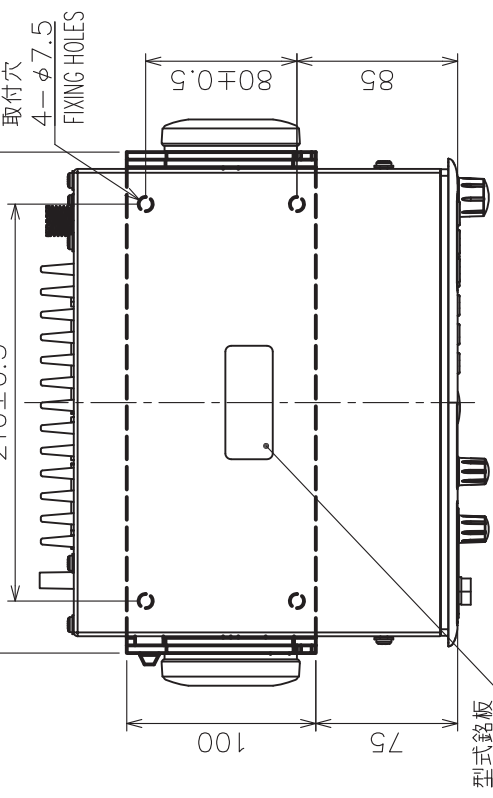
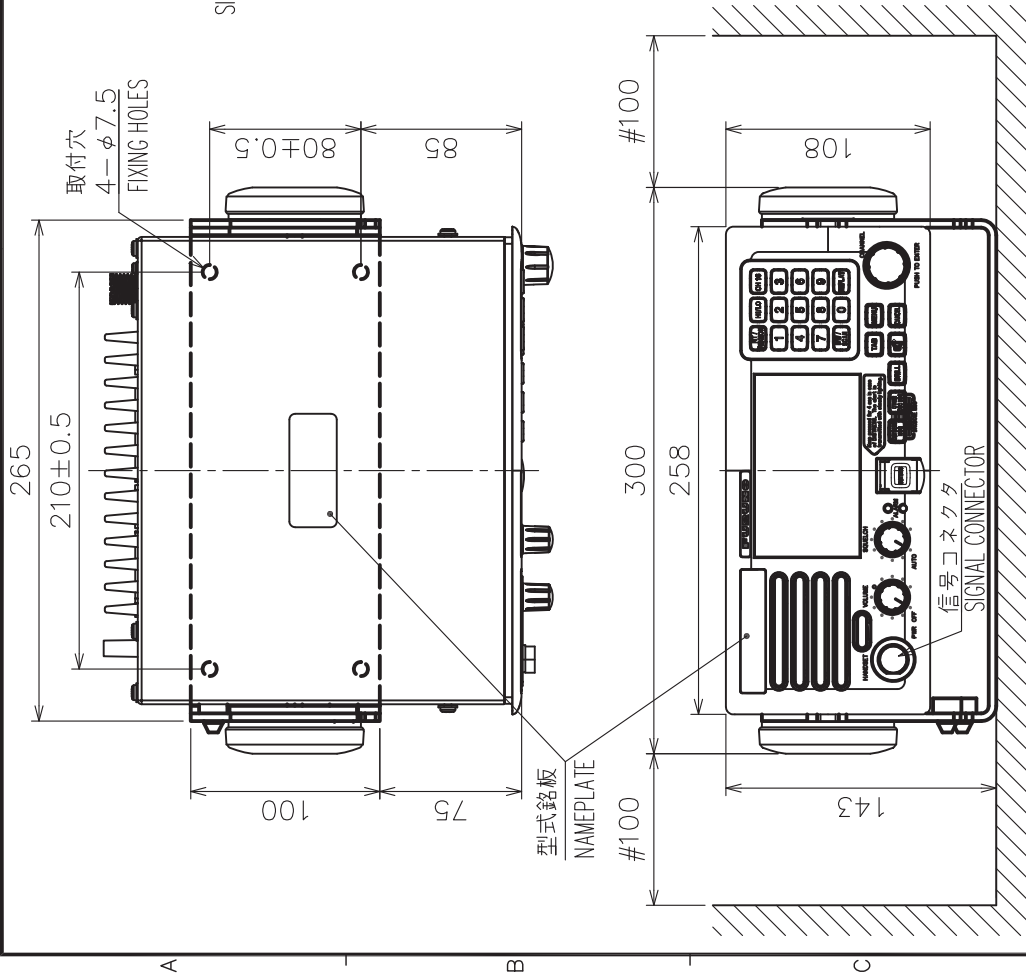
NOTE

1. TABLE 1 INDICATES TOLERANCE OF DIMENSIONS WHICH IS NOT SPECIFIED.
2. # MINIMUM SERVICE CLEARANCE.
3. USE TAPPING SCREWS $\phi 6 \times 2.0$ FOR FIXING THE UNIT.

DRAWN	25/Apr/2012 T.YAMASAKI	TITLE	FM-8900S
CHECKED	25/Apr/2012 H.MAKI	名称	送受信機 (卓上装備)
APPROVED	25/Apr/2012 Y.NISHIYAMA	外寸図	
SCALE	1/4 MASS 4.2 kg	NAME	TRANSCEIVER UNIT (TABLETOP MOUNT)
DMC No.	C5680-G01-B	REF.No.	05-104-250G-2
		OUTLINE DRAWING	



表1 TABLE 1

寸法区分 (mm) DIMENSION	公差 (mm) TOLERANCE
L ≤ 50	±1.5
50 < L ≤ 100	±2.5
100 < L ≤ 500	±3

注 記

- 1) 指定外の寸法公差は表1による。
- 2) #印寸法は最小サービス空間寸法とする。
- 3) 取付用ネジは+トラスタッピンネジ呼び径5×15を使用のこと。

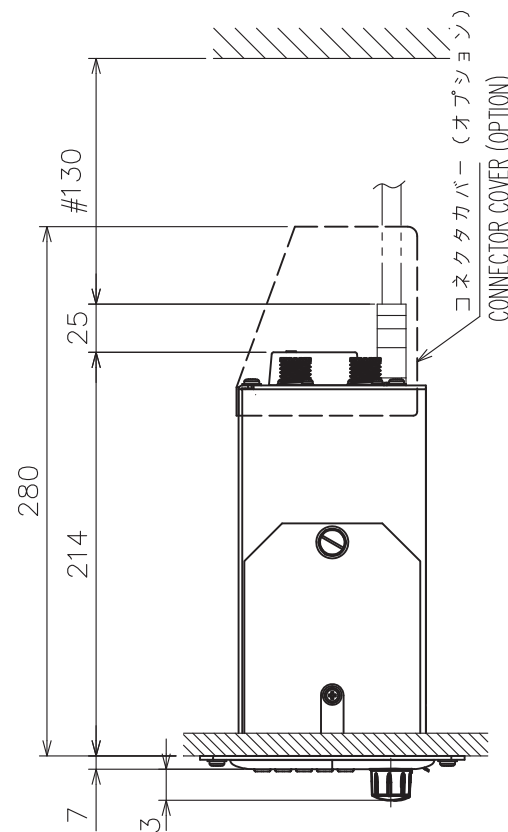
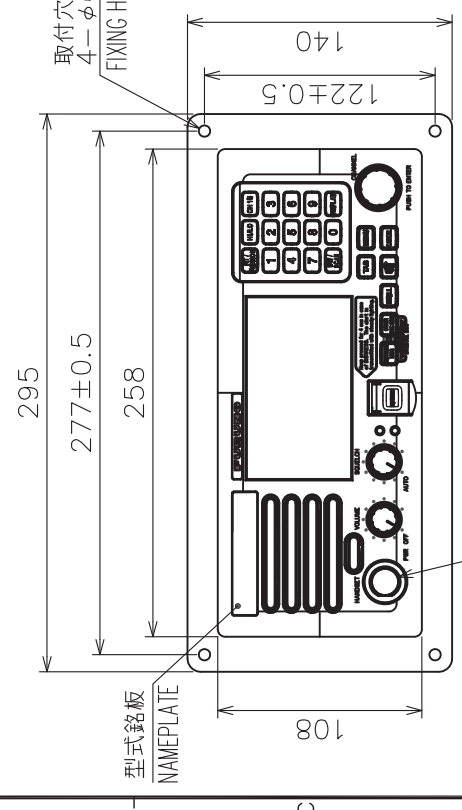
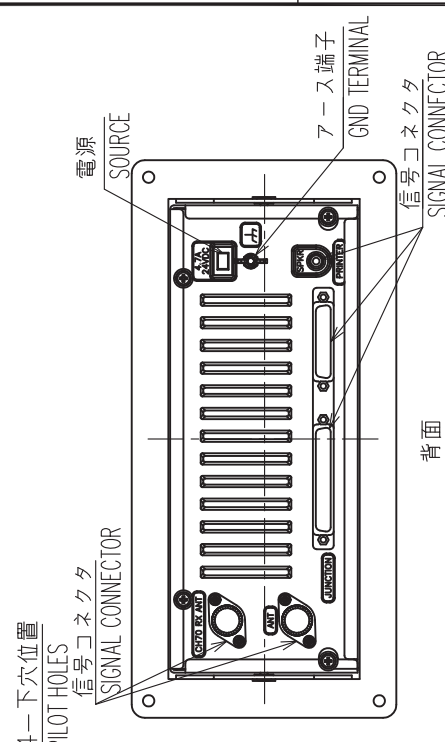
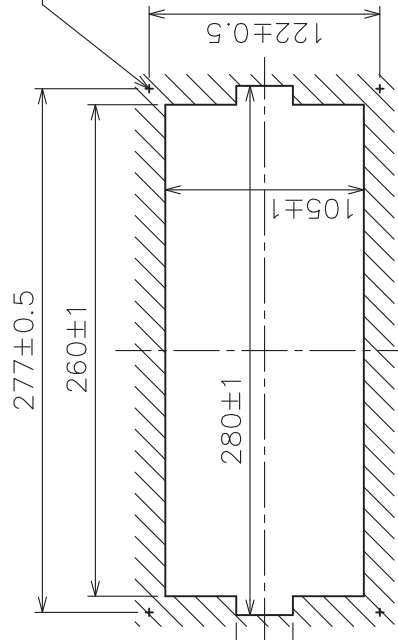
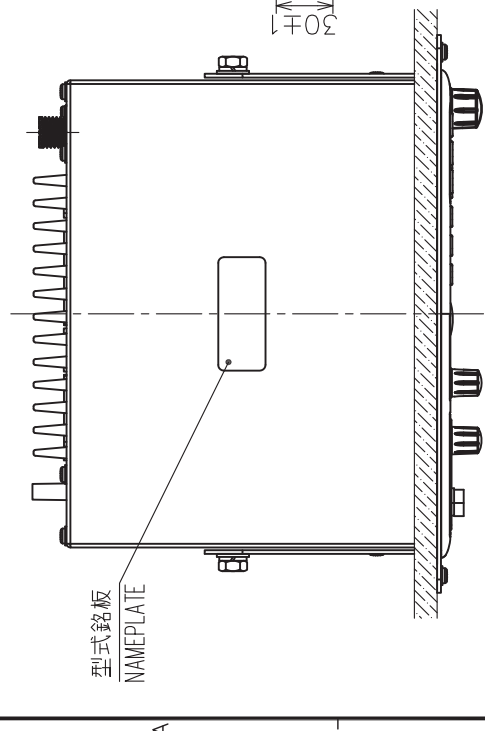
NOTE

1. TABLE 1 INDICATES TOLERANCE OF DIMENSIONS WHICH IS NOT SPECIFIED.
2. # MINIMUM SERVICE CLEARANCE.
3. USE TAPPING SCREWS φ5x15 FOR FIXING THE UNIT.

DRAWN	25/Apr/2012 I.YAMASAKI	TITLE	FM-8900S
CHECKED	25/Apr/2012 H.MAKI	名称	送受信機 (埋込装置)
APPROVED	25/Apr/2012 Y.NISHIYAMA	外寸図	
SCALE	1/4 MASS 4.2 kg	NAME	TRANSCEIVER UNIT (FLUSH MOUNT)
DWG.No.	C5680-G02-B	REF.No.	05-104-251G-2
			OUTLINE DRAWING

ハンドセット
HS-8900
HANDSET

ハンドセットハンガー
HG-8900
HANDSET HANGER

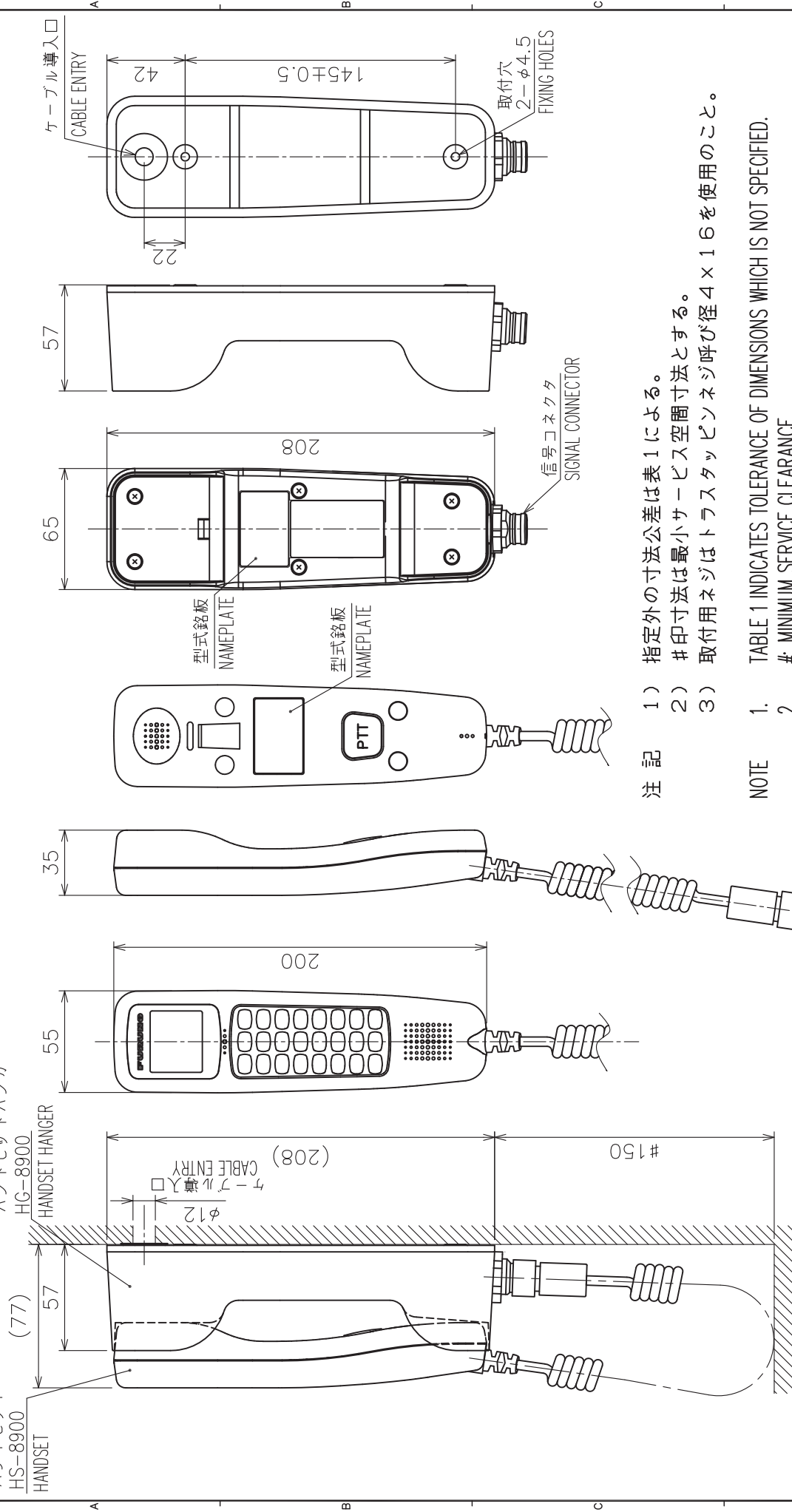

- 注記 1) 指定外の寸法公差は表1による。
 2) #印寸法は最小サービスクリアランスとする。
 3) 取付用ネジはトラスタップピンネジ呼び径4×16を使用のこと。

NOTE 1. TABLE 1 INDICATES TOLERANCE OF DIMENSIONS WHICH IS NOT SPECIFIED.
 2. #: MINIMUM SERVICE CLEARANCE.
 3. USE TAPPING SCREWS $\phi 4 \times 16$ FOR FIXING THE UNIT.

DRAWN	26/Dec/2011	I.YAMASAKI	TITLE	RB-8900, HG-8900
CHECKED	26/Dec/2011	H.MAKI	名称	リモートステーション
APPROVED	27/Dec/2011	Y.NISHIYAMA	外寸図	
SCALE	1/3	100% 質量ハンダセットハンガーを含む。 kg MASS INCLUDES HANDSET/HANGER.	NAME	REMOTE STATION
DWG.No.	C5680-603-A	REF.No.	05-104-550G-1	OUTLINE DRAWING

表1 TABLE 1

寸法区分 (mm) DIMENSION	公差 (mm) TOLERANCE
L ≤ 50	±1.5
50 < L ≤ 100	±2.5
100 < L ≤ 500	±3

取付穴
4-φ6
FIXING HOLES

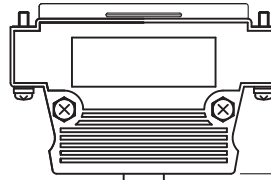
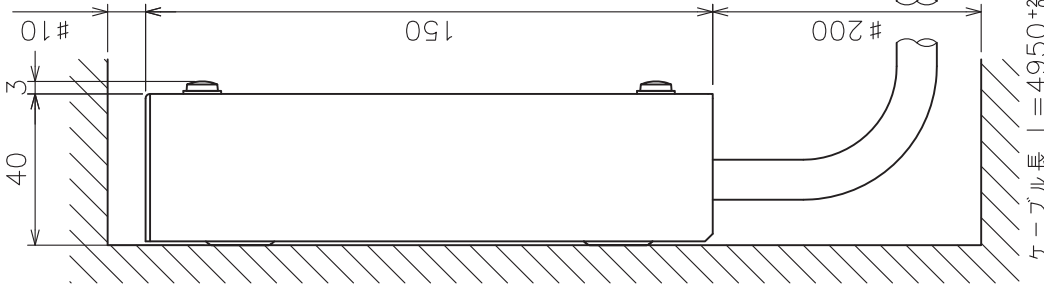

240±0.7

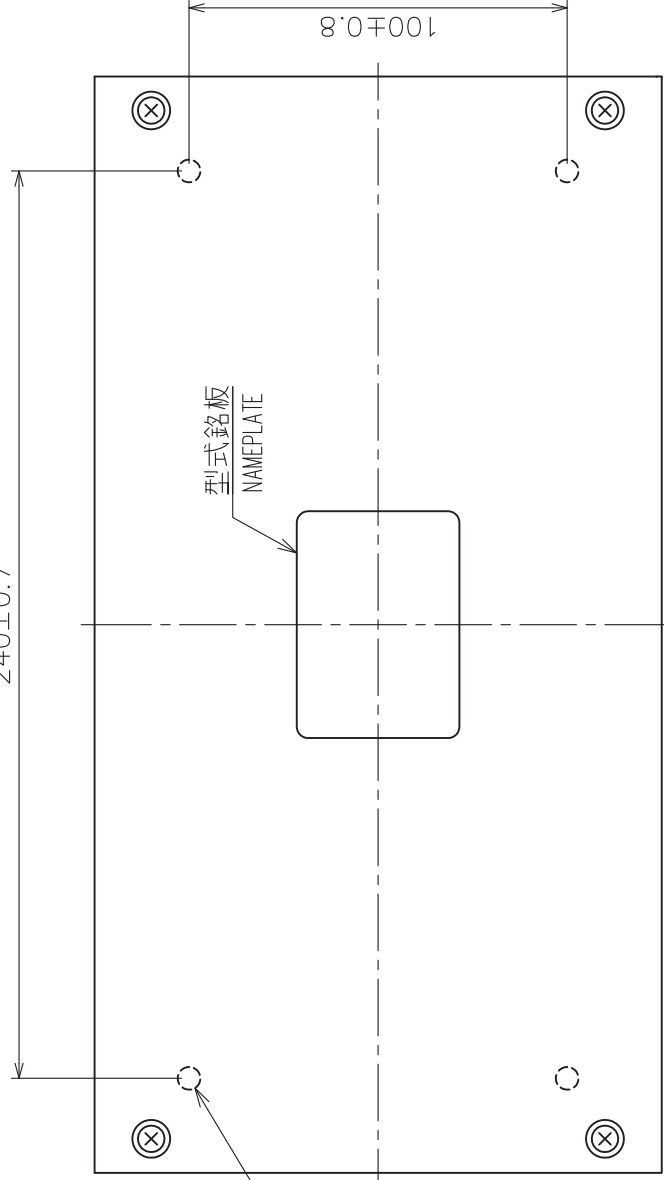

付属ケーブル
ATTACHED CABLE

ケーブル導入口
CABLE ENTRY

許容ケーブル径
MAXIMUM CABLE DIA.
φ15 MAX.

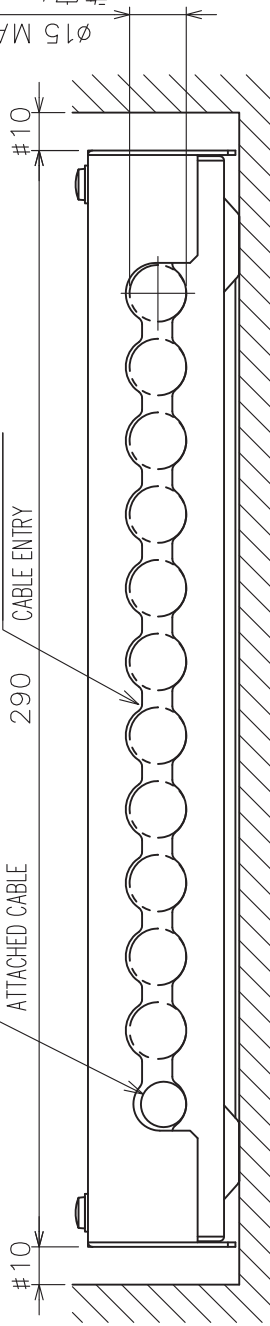

注 記

- 1) 指定外の寸法公差は表1による。
- 2) #印寸法は最小サービスクリアランスとする。
- 3) 取付用ネジはトラスチックピンネジ呼び径5×20を使用のこと。

NOTE

1. TABLE 1 INDICATES TOLERANCE OF DIMENSIONS WHICH IS NOT SPECIFIED.
2. # MINIMUM SERVICE CLEARANCE.
3. USE TAPPING SCREWS φ5x20 FOR FIXING THE UNIT.

DRAWN	26/Dec/2011 T.YAMASAKI	TITLE	IF-8900
CHECKED	26/Dec/2011 H.MAKI	名称	接続箱
APPROVED	27/Dec/2011 Y.NISHIYAMA	外寸図	
SCALE	1/2 MASS 1.6 ±10% 質量はケーブルを含みず MASS DOES NOT INCLUDE CABLE.	NAME	JUNCTION BOX
DWG.No.	C5680-G04-A	REF.No.	05-104-350G-2
			OUTLINE DRAWING



表 1 TABLE 1

寸法区分 (mm) DIMENSION	公差 (mm) TOLERANCE
$L \leq 50$	± 1.5
$50 < L \leq 100$	± 2.5
$100 < L \leq 500$	± 3

注 記 指定外の寸法公差は表 1 による。
 NOTE TABLE 1 INDICATES TOLERANCE OF DIMENSIONS WHICH IS NOT SPECIFIED.

DRAWN 13/Apr/2012 T.YAMASAKI	TITLE HS-2003-15
CHECKED 13/Apr/2012 H.MAKI	名称 ハンドセット
APPROVED Y. Hatai	FM-8900S FM-8800D/S 外寸図
SCALE 1/2	MASS 0.20 ±10% kg
DWG. No. C5642-G10-D	REF. No. 05-093-200G-3
	NAME HANDSET OUTLINE DRAWING

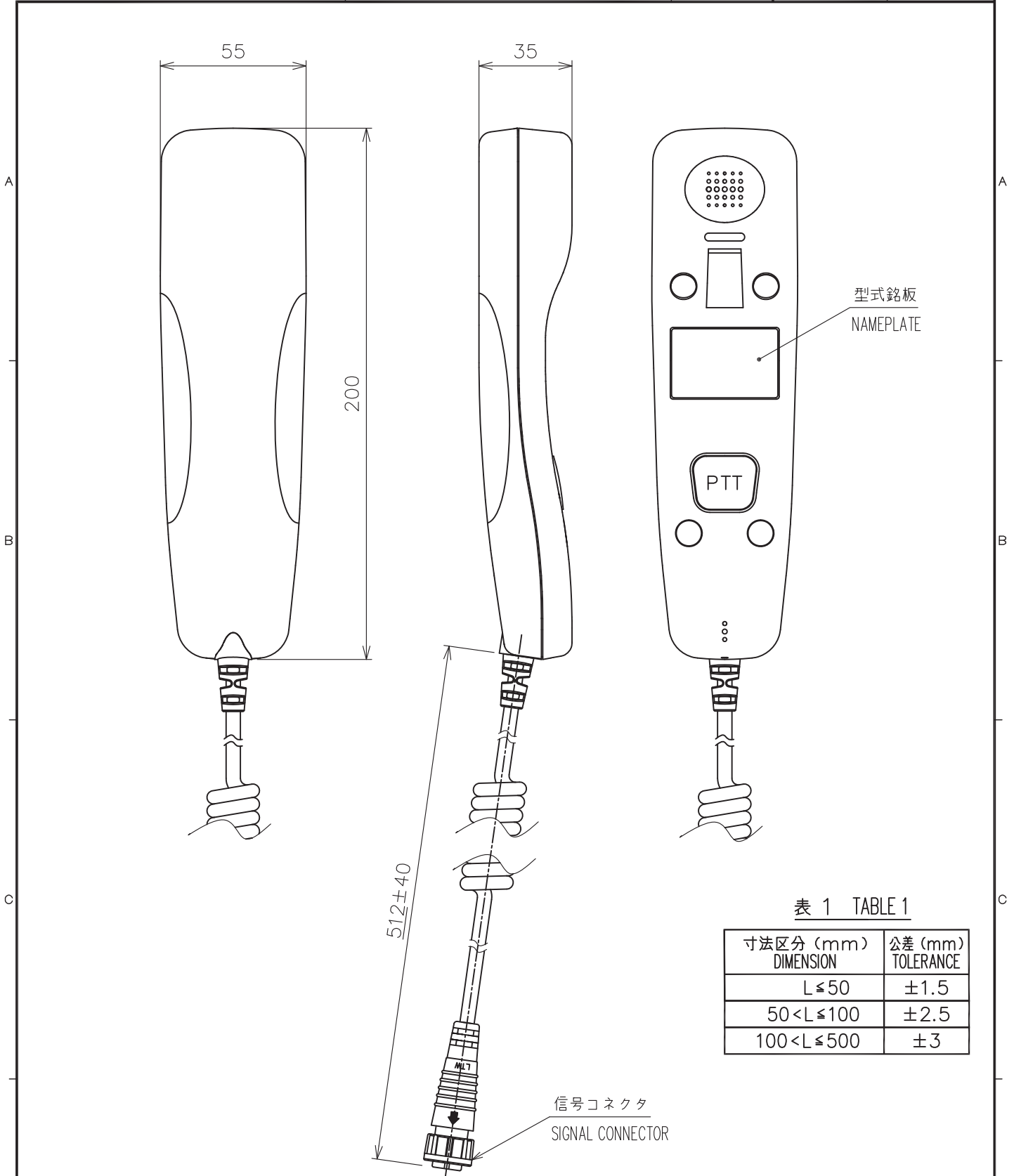
表 1 TABLE 1

寸法区分 (mm) DIMENSION	公差 (mm) TOLERANCE
L ≤ 50	± 1.5
50 < L ≤ 100	± 2.5
100 < L ≤ 500	± 3

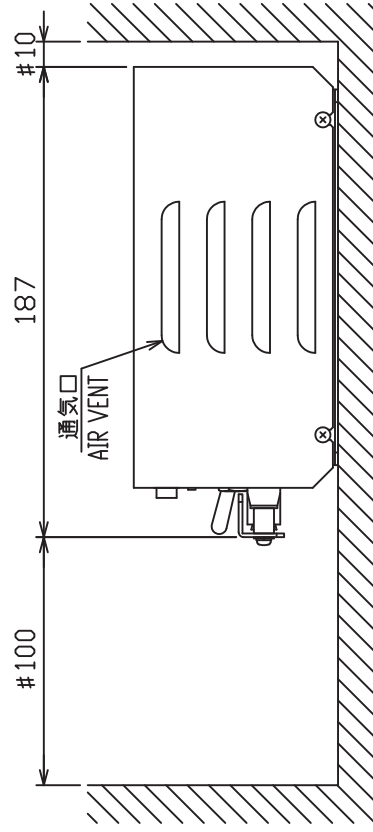
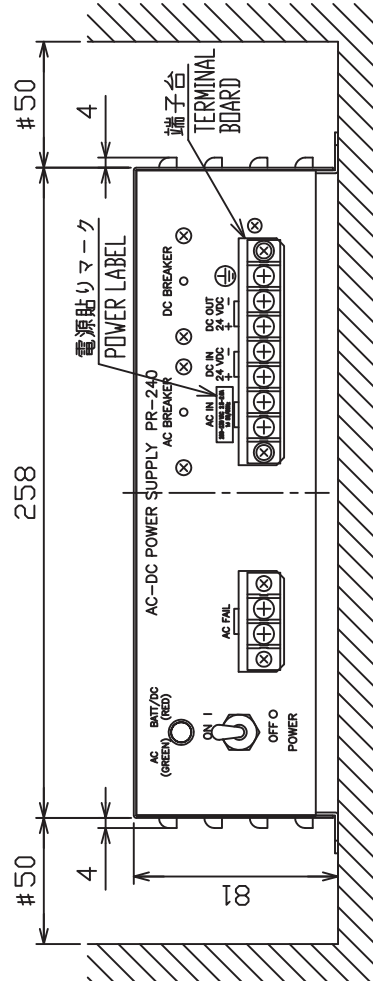
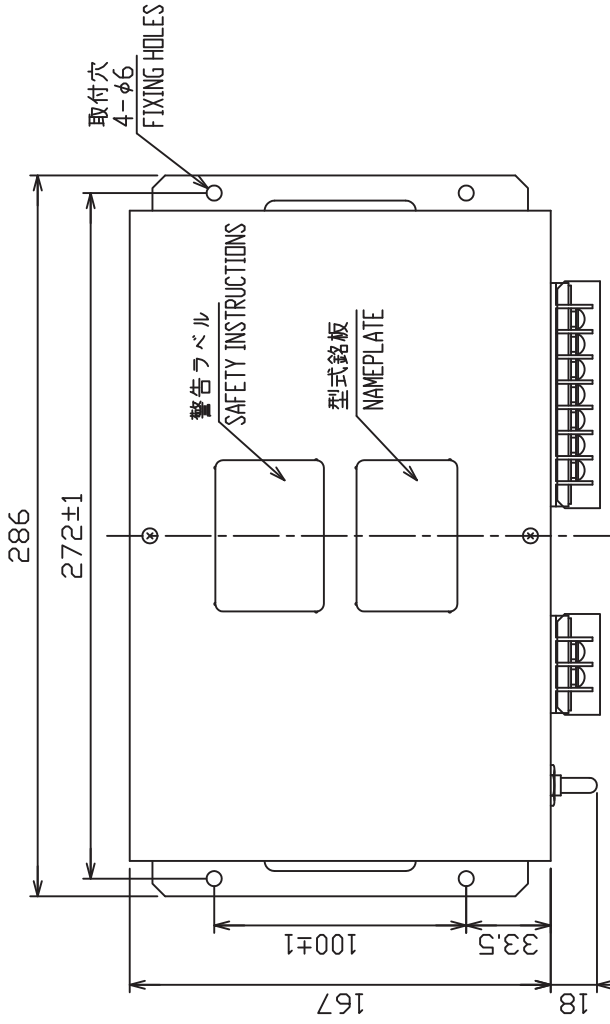

注 記 1) 指定なき寸法公差は表 1 による。
 2) #印寸法は最小サービスマージンを考慮して寸法とする。
 3) 取付用ネジは + トラスタックピンネジ 呼び径 4 × 1.6 を使用のこと。

NOTE 1. TABLE 1 INDICATES TOLERANCE OF DIMENSIONS WHICH IS NOT SPECIFIED.
 2. # MINIMUM SERVICE CLEARANCE.
 3. USE TAPPING SCREWS φ4x1.6 FOR FIXING THE UNIT.

DRAWN	25/Sep/09 T.YAMASAKI	TITLE	PR-240
CHECKED	25/Sep/09 T.TAKENO	名称	AC/DC電源ユニット
APPROVED	26/Oct/09 R.Esumi	外寸図	
SCALE	1/3	NAME	AC/DC POWER SUPPLY UNIT
DWG No.	C5003-603-J	REF. No.	24-003-500G-4
			OUTLINE DRAWING

4

3

2

1

表1 TABLE 1

寸法区分 (mm) DIMENSION	公差 (mm) TOLERANCE
L ≤ 50	±1.5
50 < L ≤ 100	±2.5
100 < L ≤ 500	±3

- 注記 1) 指定外の寸法公差は表1による。
 2) #印寸法は最小サービスペース寸法とする。
 3) 取付用ネジはトラスタツピンネジ呼び径5×20を使用のこと。
- NOTE 1. TABLE 1 INDICATES TOLERANCE OF DIMENSIONS WHICH IS NOT SPECIFIED.
 2. # MINIMUM SERVICE CLEARANCE.
 3. USE TAPPING SCREWS $\phi 5 \times 20$ FOR FIXING THE UNIT.

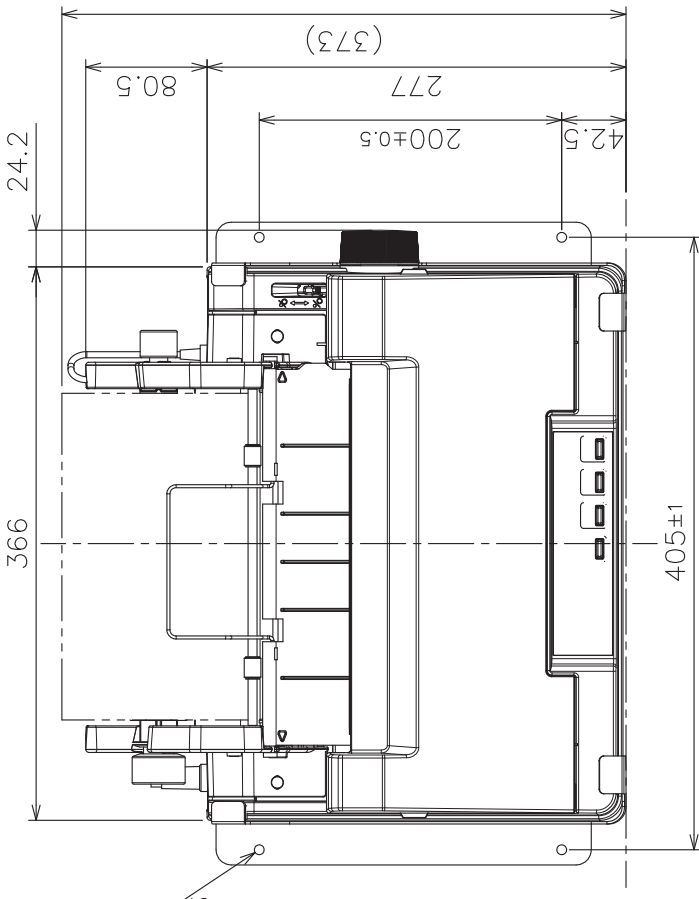

取付穴
4 × φ6.5
FIXING HOLES

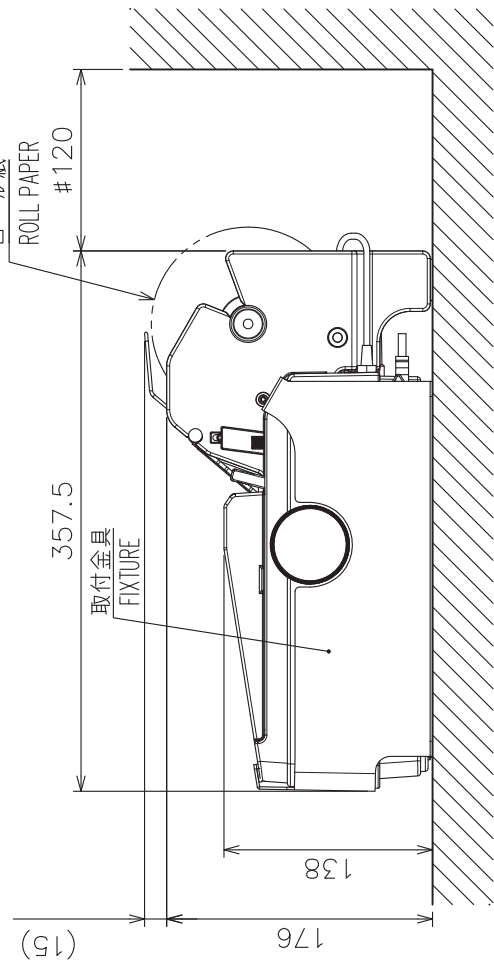

(15)

DRAWN	6/Jul/2012	I. YAMASAKI	TITLE	PP-520
CHECKED	6/Jul/2012	H. MAKI	名#	プリンタ
APPROVED			外寸図	
SCALE	1/5	質量はロール紙を含まず kg MASS DOES NOT INCLUDE ROLL PAPER	NAME	PRINTER
DWG. No.	C5080-G02-A	REF. No.	16-023-551G-1	OUTLINE DRAWING

A

B

C

表1 TABLE 1

寸法区分 (mm) DIMENSION	公差 (mm) TOLERANCE
L ≤ 50	±1.5
50 < L ≤ 100	±2.5
100 < L ≤ 500	±3

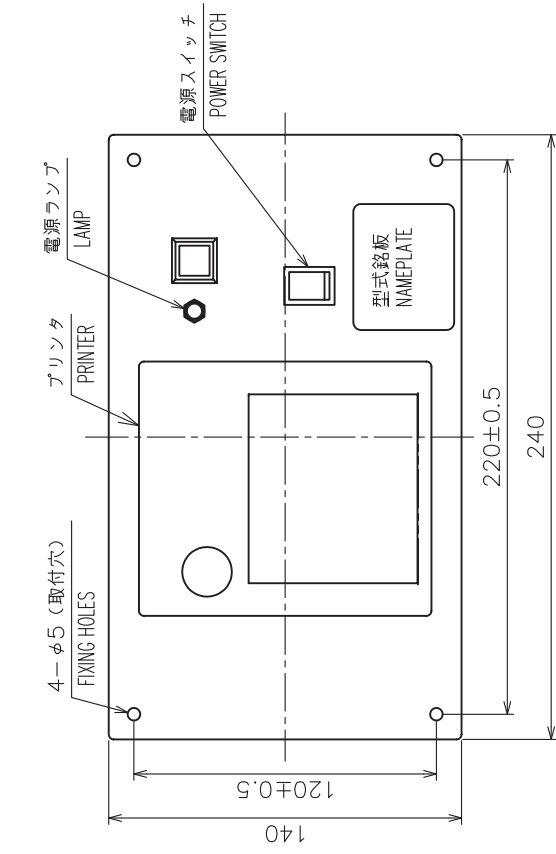
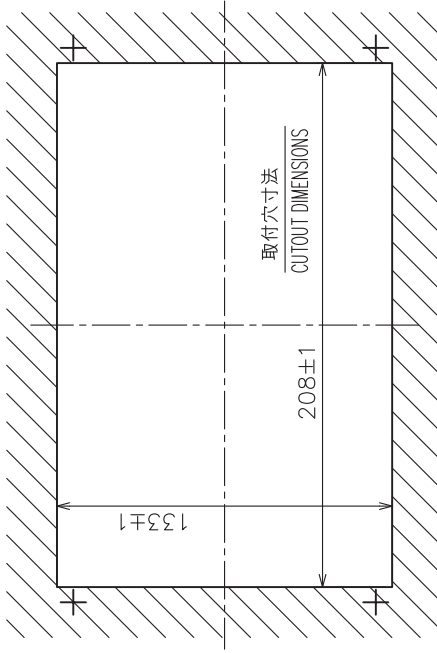
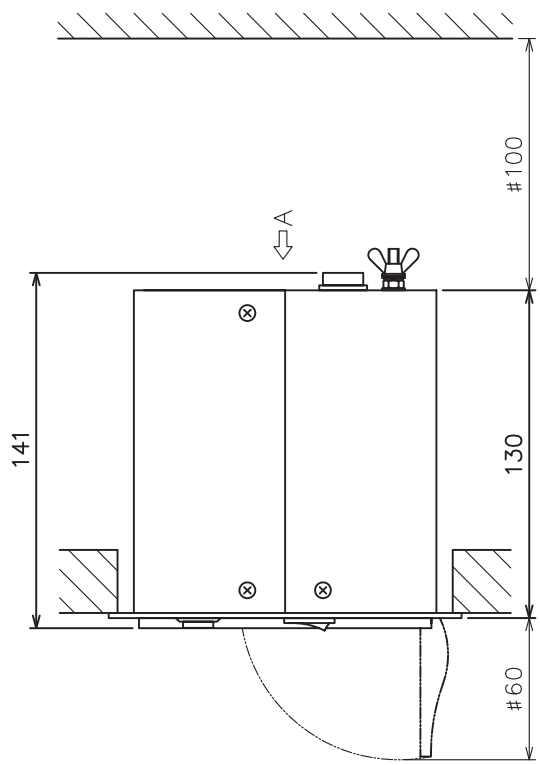
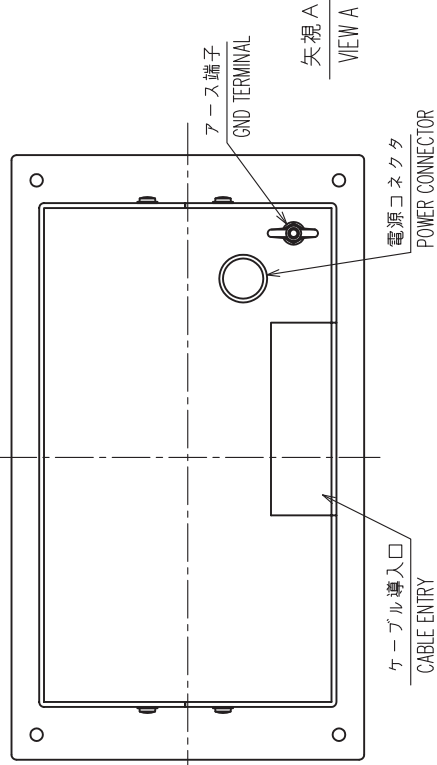

- 注記 1) #印寸法は最小サービス空間寸法とする。
 2) 指定外の寸法公差は表1による。
 3) 取付用ネジはトラスタックピンネジ呼び径4×16を使用のこと。
- NOTE 1. # MINIMUM SERVICE CLEARANCE.
 2. TABLE 1 INDICATES TOLERANCE OF DIMENSIONS WHICH IS NOT SPECIFIED.
 3. USE TAPPING SCREWS 4x16 FOR FIXING THE UNIT.

DRAWN	29/Aug/2016	T.YAMASAKI	TITLE	PP-8800A
CHECKED	29/Aug/2016	H.MAKI	各 種	プリンタ (埋込装備)
APPROVED	30/Aug/2016	H.MAKI	NAME	外寸図
SCALE	1/3	1/3	FM-8800/S	PRINTER (FLUSH MOUNT)
DWG.No.	C5642-G16-C	REF.No.	05-093-791G-1	OUTLINE DRAWING

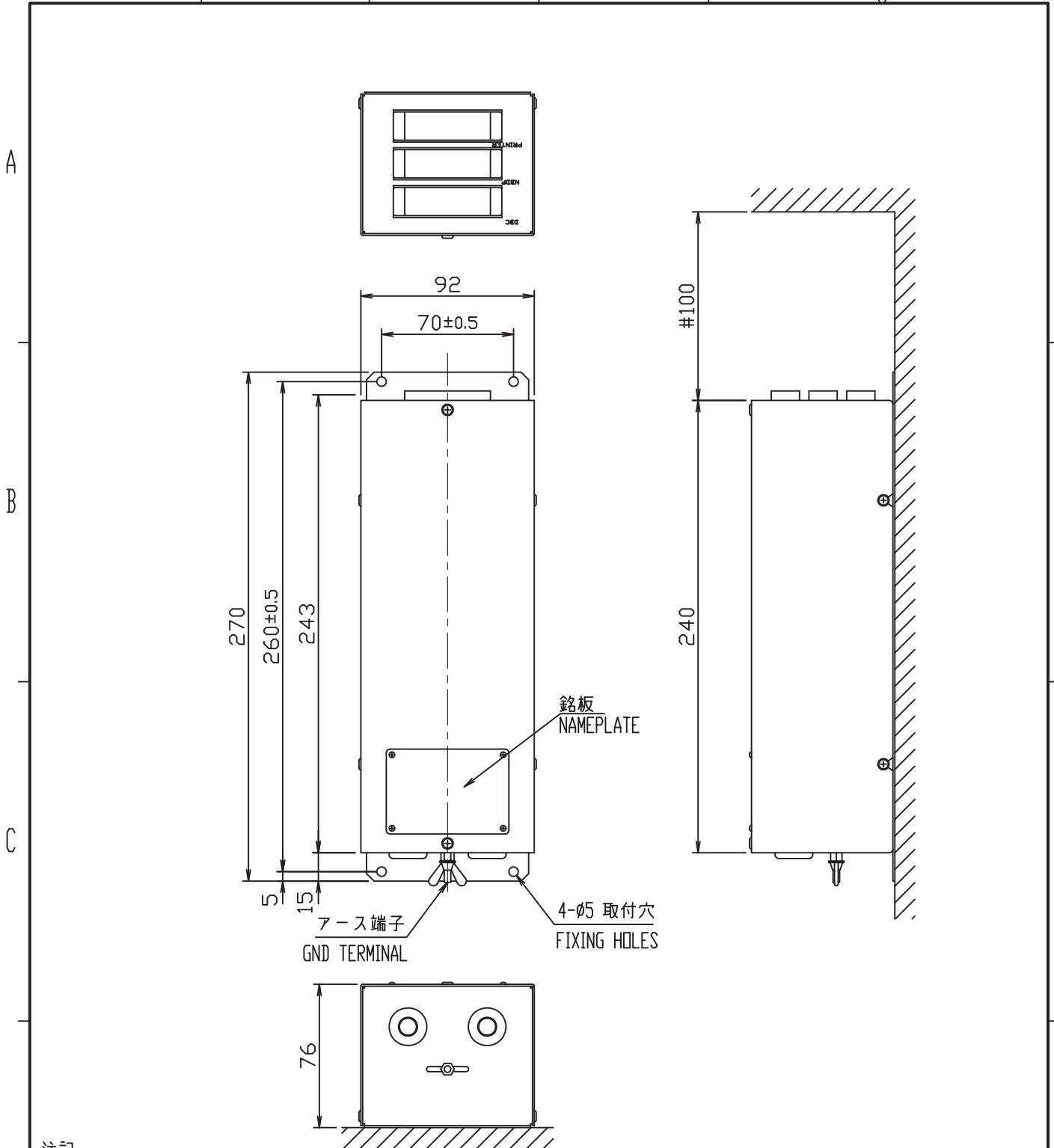

注記

- 1) 指定なき寸法公差は表1による。
- 2) #: 最小サービス空間寸法。

NOTE

1. TABLE 1 INDICATES TOLERANCE OF DIMENSIONS WHICH IS NOT SPECIFIED.
2. #: MINIMUM SERVICE CLEARANCE.

表1 TABLE_1

寸法区分(mm) DIMENSION	公差(mm) TOLERANCE
0 < L ≤ 50	±1.5
50 < L ≤ 100	±2.5
100 < L ≤ 500	±3

DRAWN Sep. 6 '06 T.YAMASAKI	TITLE IF-8500
CHECKED Sep. 6 '06 T.TAKENO	名称 プリンターインターフェイス
APPROVED Sep. 21 '06 T.Matsuguchi	外寸図
SCALE 1/3	NAME PRINTER INTERFACE
MASS 0.7 ±10% kg	
DWG.No. C5603-G05- C	05-073-2100-G1 OUTLINE DRAWING

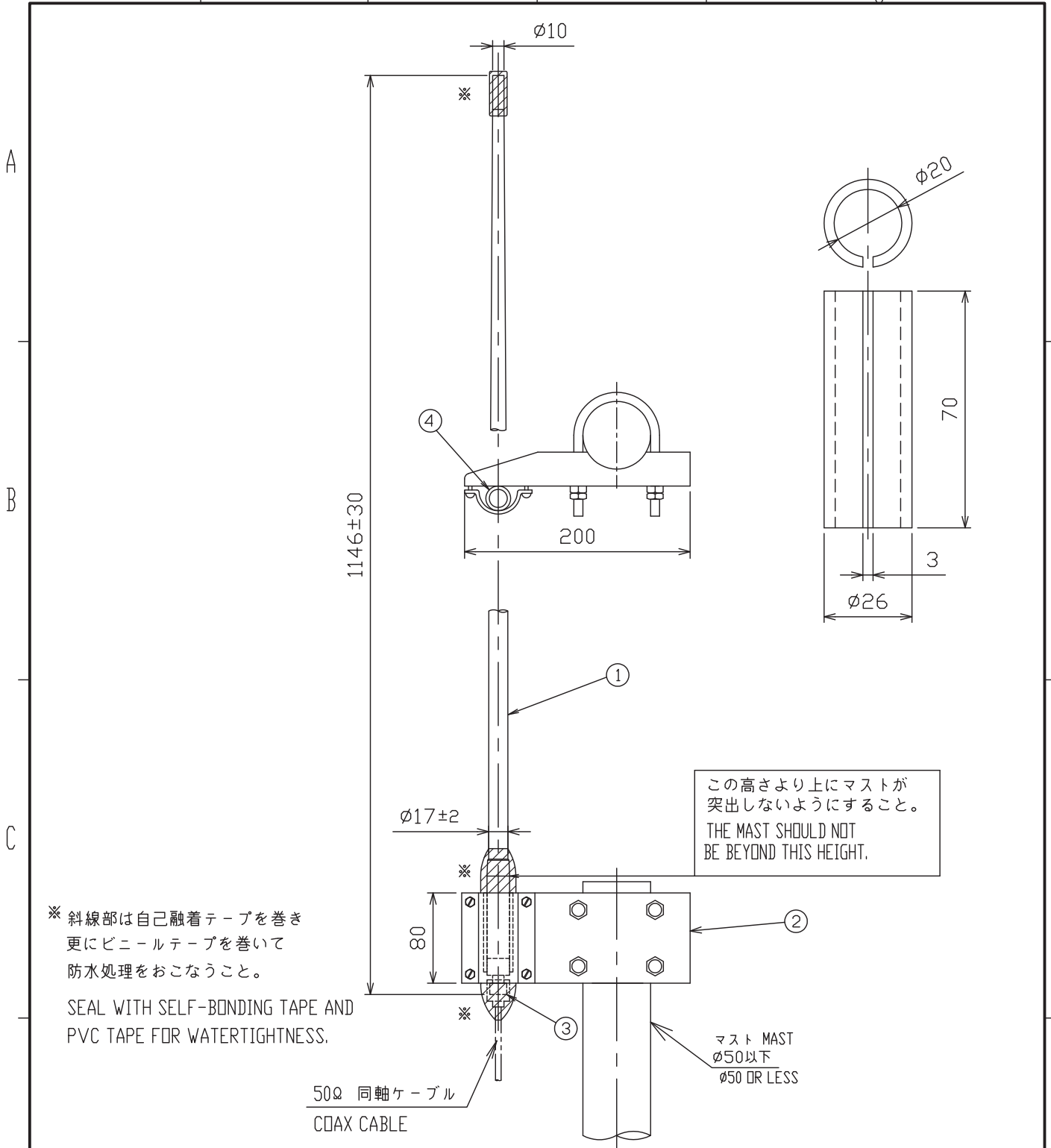

品番 ITEM	品名 NAME	材質 MATERIAL	数量 Q.TY	図番 DWG.No.	摘要 REMARKS
4	固定用パイプ LINER PIPE	硬質塩ビ VINYL CHLORIDE	1		
3	同軸コネクタ COAX. CONNECTOR		1		M-R
2	アンテナ取付金具 ANTENNA BRACKET	SUS	1 式 SET	4-310071	0.6kg
1	アンテナ棒 ANTENNA ELEMENT	FRP	1		0.25kg

DRAWN	4/Aug/2017	I.YAMASAKI	TITLE	FAB-151D
CHECKED	4/Aug/2017	H.MAKI	名称	150MHz ホイップアンテナ
APPROVED	10/Aug/2017	H.MAKI		外寸図
SCALE	1/5	MASS 0.85 ±10% kg	NAME	150MHz WHIP ANTENNA
DWG.No.	C5013-019-L	4-110718		OUTLINE DRAWING

表1 (Table1)

寸法区分 (mm) Dimension	公差 (mm) Tolerance
$L \leq 50$	± 1.5
$50 < L \leq 100$	± 2.5
$100 < L \leq 500$	± 3
$500 < L \leq 1000$	± 4
$1000 < L \leq 2000$	± 5

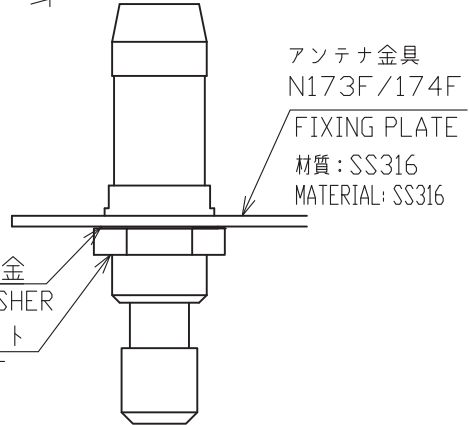
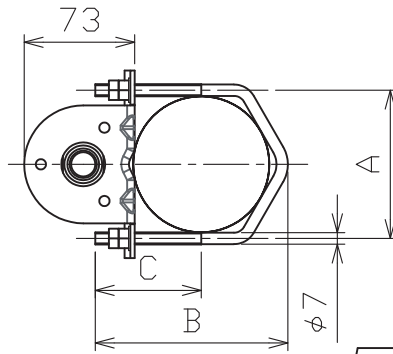

取付部詳細 (尺度:1/2)
DETAIL FOR FIXING (SCALE:1/2)

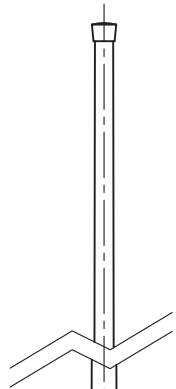

*:斜線部は自己融着テープを巻きさらにビニールテープを巻いて防水処理をすること。
塗りつぶし部はシリコンを塗布すること。
SEAL WITH SELF-BONDING TAPE AND PVC TAPE FOR WATERTIGHT.
APPLY SILICONE SEALANT ONTO THE GAP WHICH IS INDICATED WITH SOLID PART.

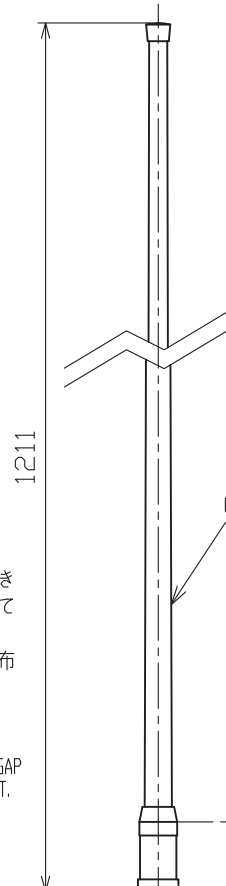

マストがこの高さより上に突出しないこと。
MAST SHOULD NOT BE BEYOND THIS HEIGHT.

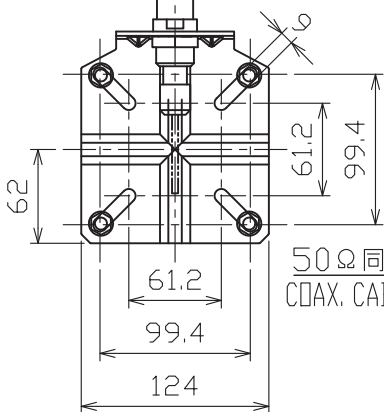

50Ω同軸ケーブル
COAX. CABLE (50Ω)

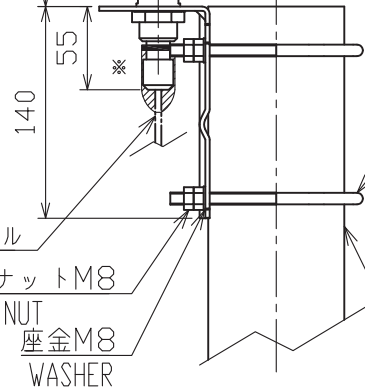

Uボルト
U-BOLT

マスト (垂直)
MAST (VERTICAL)

マスト (水平)
MAST (HORIZONTAL)

表2 (Table2)

アンテナ金具型式 FIXING PLATE	Uボルト型式 U-BOLT TYPE	適合マスト径 MAST DIAMETER	A	B	C
N173F/FEC	412-0051-01	φ49 - φ90	98	127	70
N174F/FEC	412-0024-02	φ30 - φ61	69	117	83

注記 1) 指定外の寸法公差は表1による。

NOTE 1. TABLE 1 INDICATES TOLERANCE OF DIMENSIONS WHICH IS NOT SPECIFIED.

DRAWN 2/Nov/2017 T.YAMASAKI

TITLE CX4-3/FEC

CHECKED 2/Nov/2017 H.MAKI

名称 アンテナ

APPROVED 6/Nov/2017 H.MAKI

外寸図

SCALE 1/5 MASS 1.2 ±10% kg

質量は取付金具を含まず。
MASS DOES NOT INCLUDE FIXTURE.

NAME ANTENNA

DWG. No. C5013-G04-D

REF. No. 05-104-355G-2

OUTLINE DRAWING

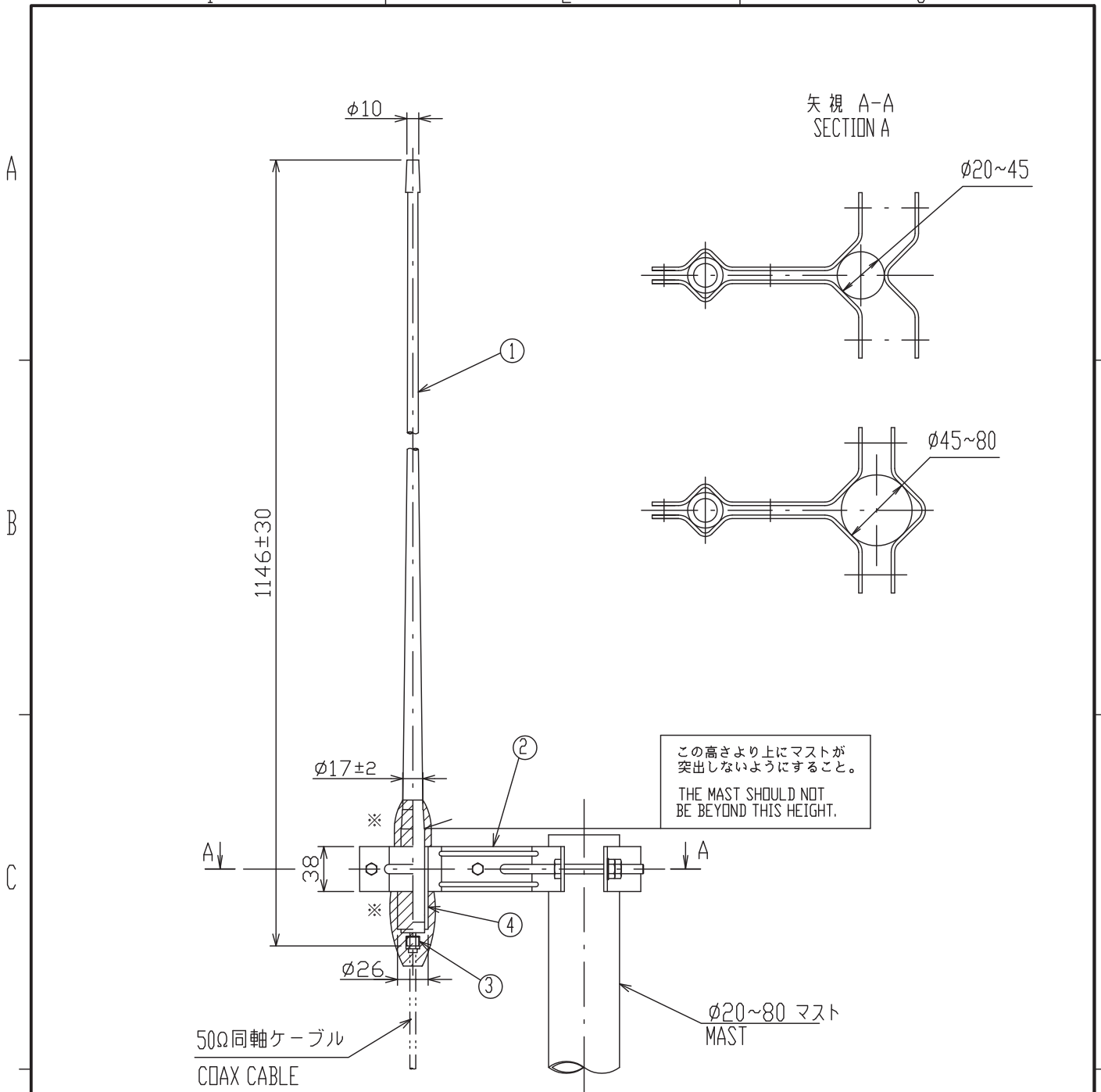

※： 斜線部は自己融着テープを巻き
さらにビニールテープを巻いて
防水処理を行うこと。
SEAL WITH SELF-BONDING TAPE AND
PVC TAPE FOR WATERTIGHTNESS.

4	固定用パイプ LINEAR PIPE	硬質塩ビ VINYL CHLORIDE	1		
3	同軸コネクタ COAX. CONNECTOR		1		M-R
2	アンテナ取付金具 ANTENNA BRACKET	SUS316L	1 式 SET	M-15AS	t2.5
1	アンテナ棒 ANTENNA ELEMENT	FRP	1	FAB-151D	0.25 kg
品番 ITEM	品 名 NAME	材 質 MATERIAL	数 量 QTY	図 番 DWG. No.	備 考 REMARKS

DRAWN	4/Aug/2017 T.YAMASAKI	TITLE	FAB-151D + M-15AS1
CHECKED	4/Aug/2017 H.MAKI	名称	150MHzホイップアンテナ(取付金具)
APPROVED	10/Aug/2017 H.MAKI	外寸図	
SCALE	1/5 MASS 0.7 ±10% kg	質量は取付金具を含む。 MASS INCLUDES BRACKET.	NAME
DWG. No.	C5011-042-G	REF. No.	OUTLINE DRAWING

表1 TABLE 1

寸法区分(mm) DIMENSIONS	公差(mm) TOLERANCE
0 < L ≤ 50	±1.5
50 < L ≤ 100	±2.5
100 < L ≤ 500	±3

A

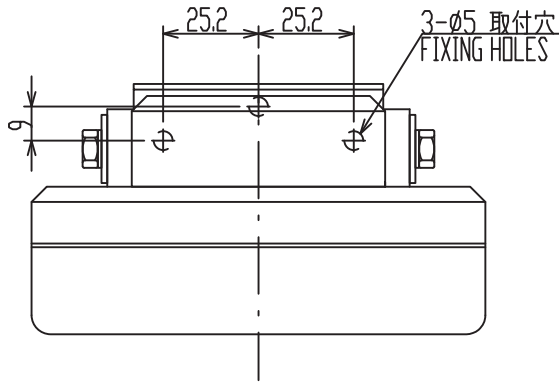

B

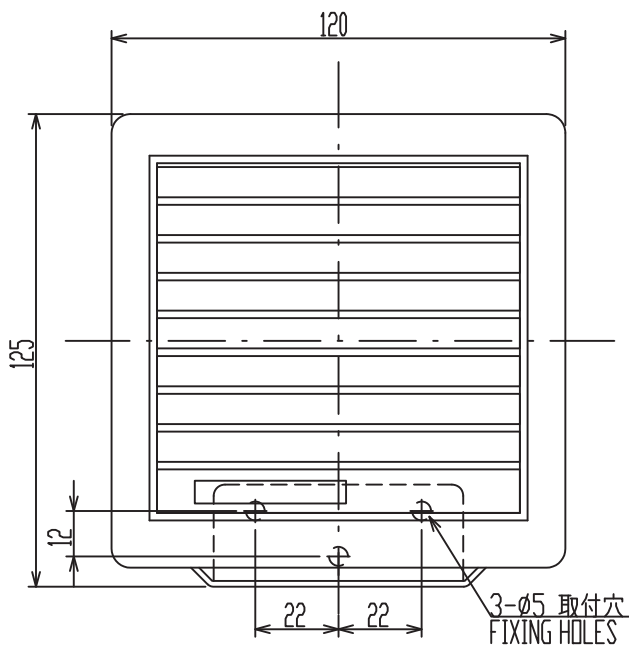

C

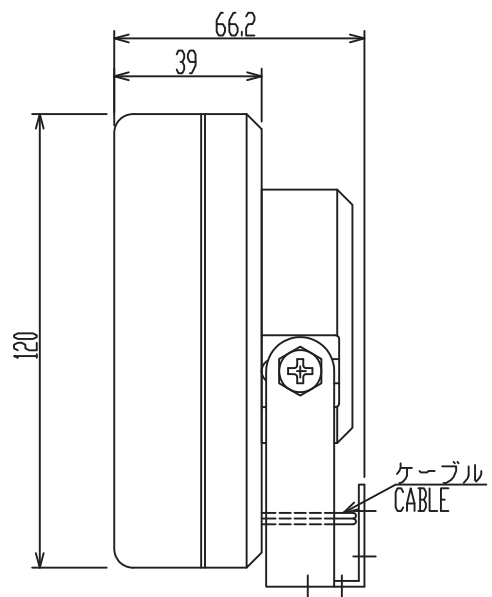

D

注記 1) 指定外寸公差は表1による。

NOTE 1. TABLE 1 INDICATES TOLERANCE OF DIMENSIONS WHICH IS NOT SPECIFIED.

DRAWN	Nov. 25, '06	E. MIYOSHI	TITLE	SEM-21Q
CHECKED		TAKAHASHI, T	名称	スピーカ
APPROVED		Y. Hatai		外寸図
SCALE	1/2	MASS 0.54 ±10% kg	質量は2.8mケーブルを含む MASS W/ 2.8m CABLE	NAME
DWG.No.	C5016-G07-C	REF.No.		LOUDSPEAKER
				OUTLINE DRAWING

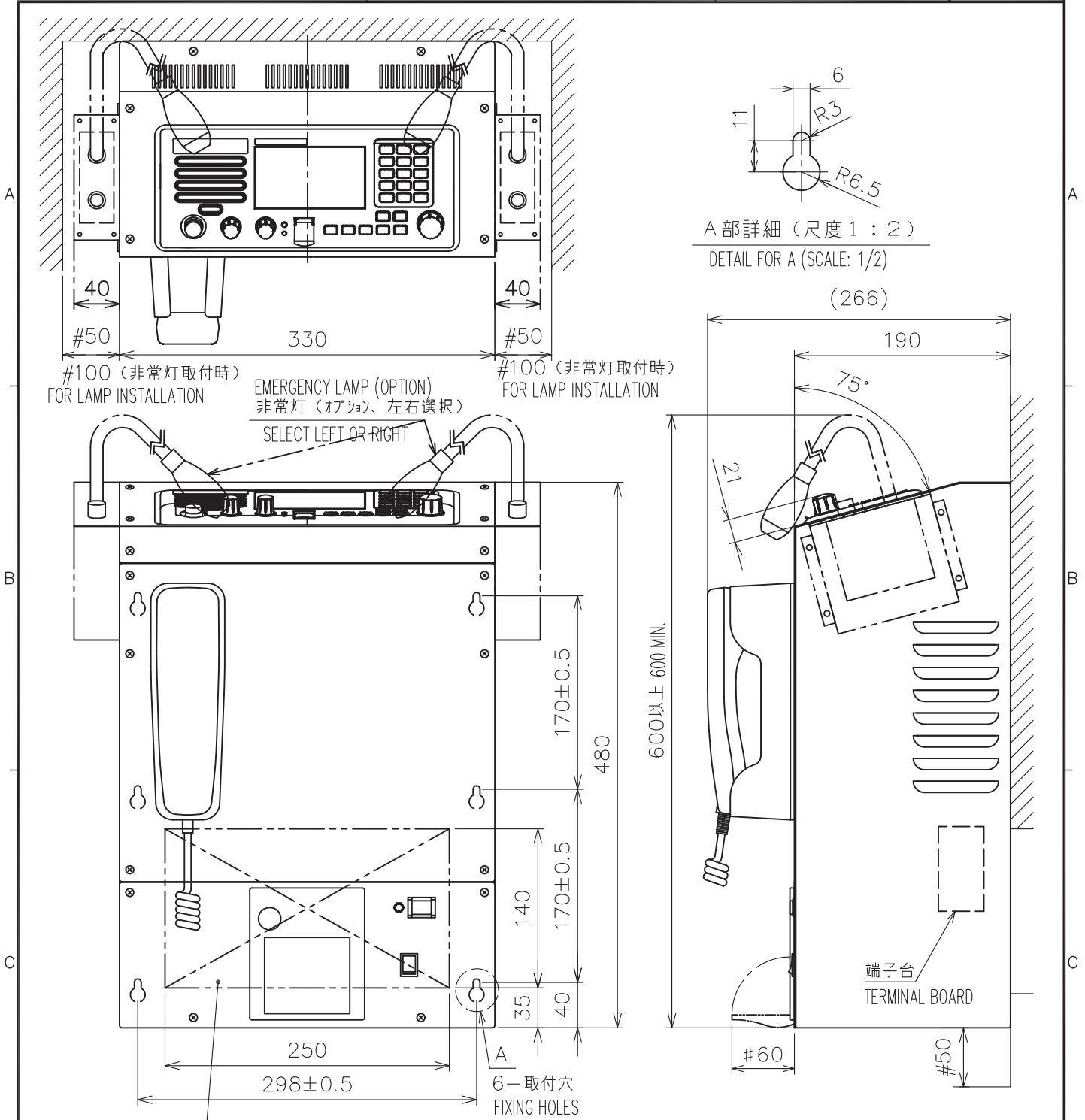

#100 (非常灯取付時) FOR LAMP INSTALLATION

EMERGENCY LAMP (OPTION)
非常灯 (オプション、左右選択)

SELECT LEFT OR RIGHT

#100 (非常灯取付時) FOR LAMP INSTALLATION

A 部詳細 (尺度 1 : 2)
DETAIL FOR A (SCALE: 1/2)

(266)

端子台
TERMINAL BOARD

配線用穴 (壁側)
CABLE ENTRY (REAR)

6-取付穴
FIXING HOLES

表 1 TABLE 1

寸法区分 (mm) DIMENSION	公差 (mm) TOLERANCE
L ≤ 50	±1.5
50 < L ≤ 100	±2.5
100 < L ≤ 500	±3
500 < L ≤ 1000	±4

注 記 1) 指定外の寸法公差は表 1 による。
2) #印寸法は最小サービス空間とする。

NOTE 1. TABLE 1 INDICATES TOLERANCE OF DIMENSIONS WHICH IS NOT SPECIFIED.
2. #: MINIMUM SERVICE CLEARANCE.

DRAWN 7/Mar/2014 T.YAMASAKI	TITLE RC-8900-SA
CHECKED 7/Mar/2014 H.MAKI	名称 VHFコンソール (壁掛ラック、プリンタ付)
APPROVED 7/Mar/2014 H.MAKI	外寸図
SCALE 1/5	NAME VHF CONSOLE (RACK W/ PRINTER)
MASS 15 ±10% kg	質量はプリンタを含む。 MASS INCLUDES PRINTER.
DWG. No. C5680-G05-E	REF. No. 05-104-850G-7
	OUTLINE DRAWING

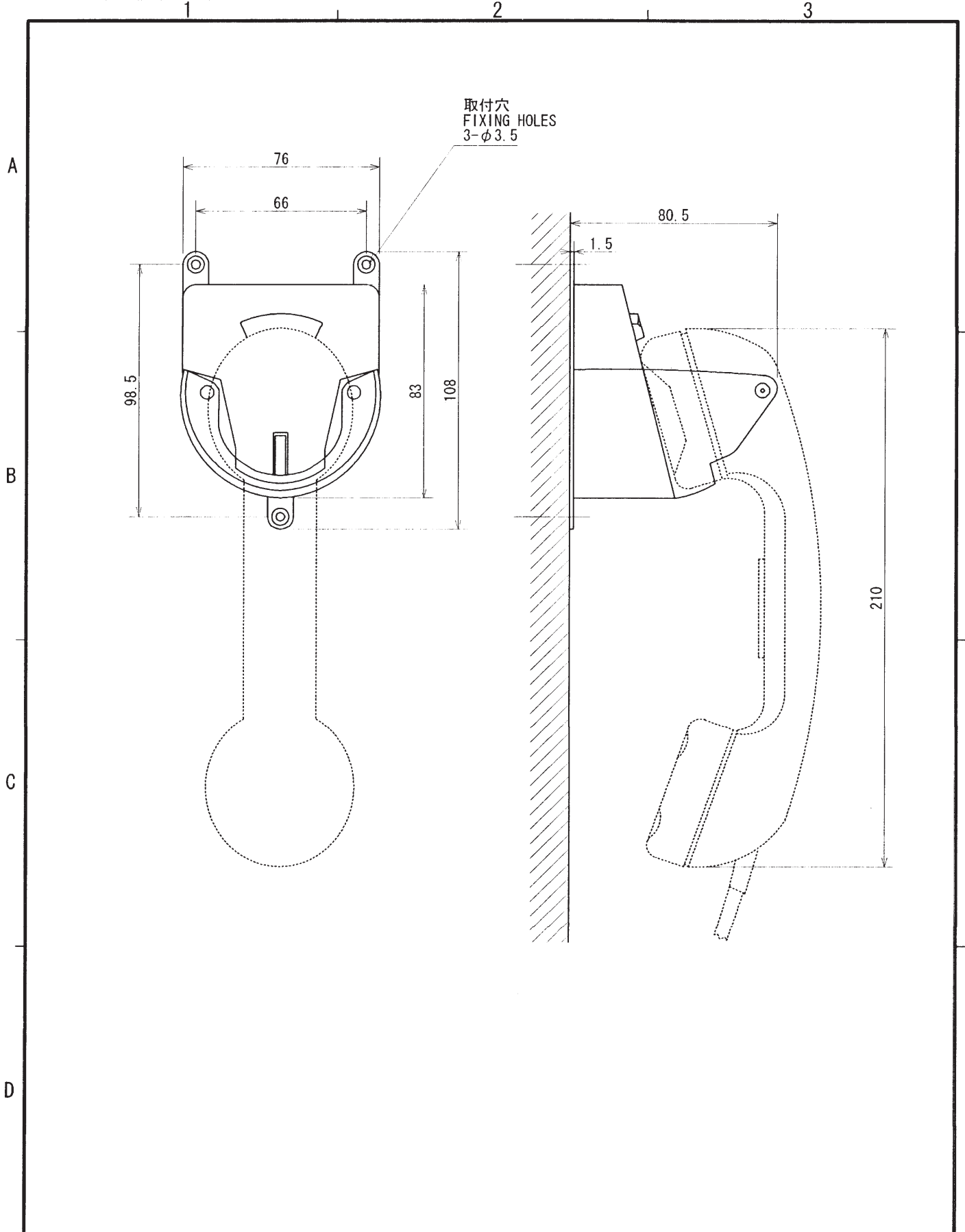

DRAWN <i>Aug 16 '00 T. YAMASAKI</i>	TITLE AP-102
CHECKED <i>Aug 16 '00 Y. Kuri</i>	名称 ハンドセットハンガー
APPROVED <i>Aug 16 '00 Y. Kuri</i>	外寸図
SCALE 1/2 MASS 0.5 kg	NAME HANDSET HANGER
DWG. No. C5015-G05-B	OUTLINE DRAWING

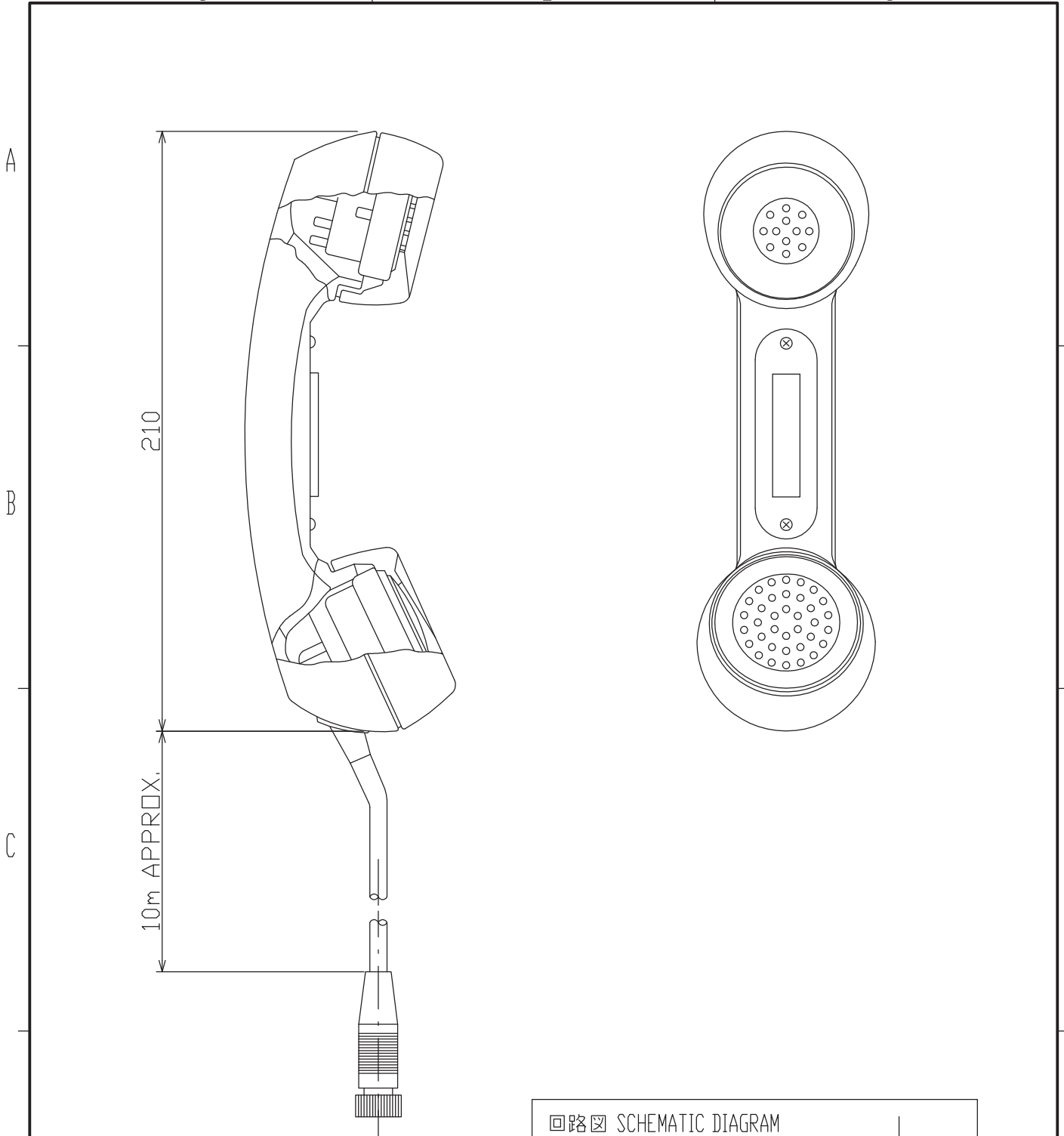

材質 MATERIAL	A B S樹脂 ABS RESIN
色 COLOR	黒 BLACK

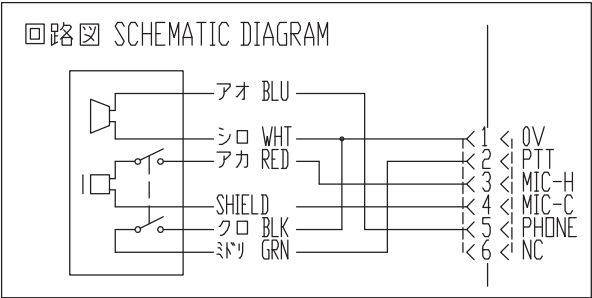

DRAWN Dec. 22 '03 T.YAMASAKI	TITLE HS-6000F Z11
CHECKED Dec. 22 '03 T.TAKENO	名称 ハンドセット
APPROVED Dec. 26 '03 <i>Matsuyuchi</i>	外寸図
SCALE 1/2 MASS 0.5 kg	NAME HANDSET
DWG.No. C5015-G11-A	OUTLINE DRAWING

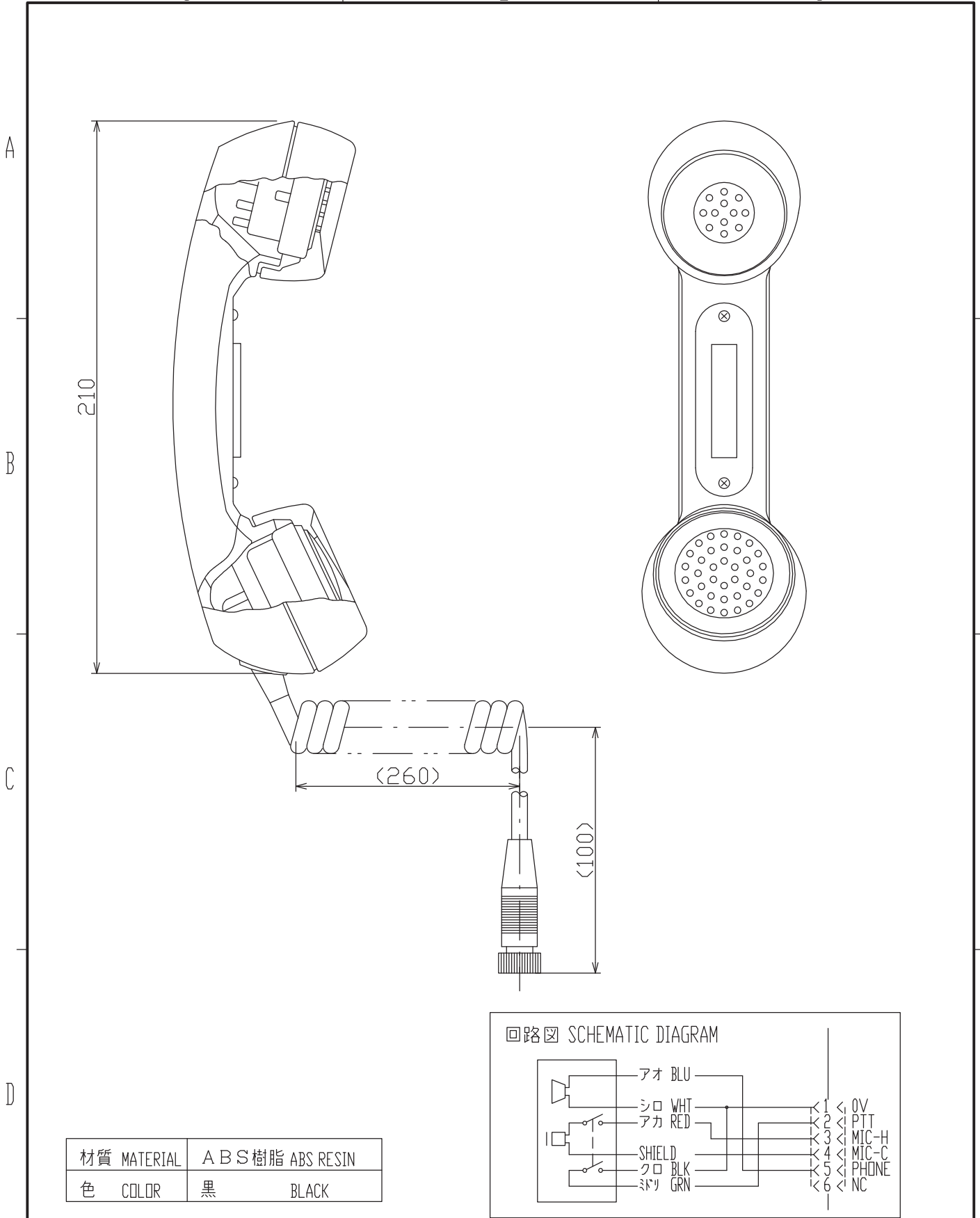

DRAWN Dec. 22 '03 T.YAMASAKI	TITLE HS-6000FZ5
CHECKED Dec. 22 '03 T.TAKENO	名称 ハンドセット
APPROVED Dec. 26 '03 <i>Matsuyuchi</i>	外寸図
SCALE 1/2 MASS 0.3 kg	NAME HANDSET
DWG.No. C5015-024-D	OUTLINE DRAWING

A

B

C

D

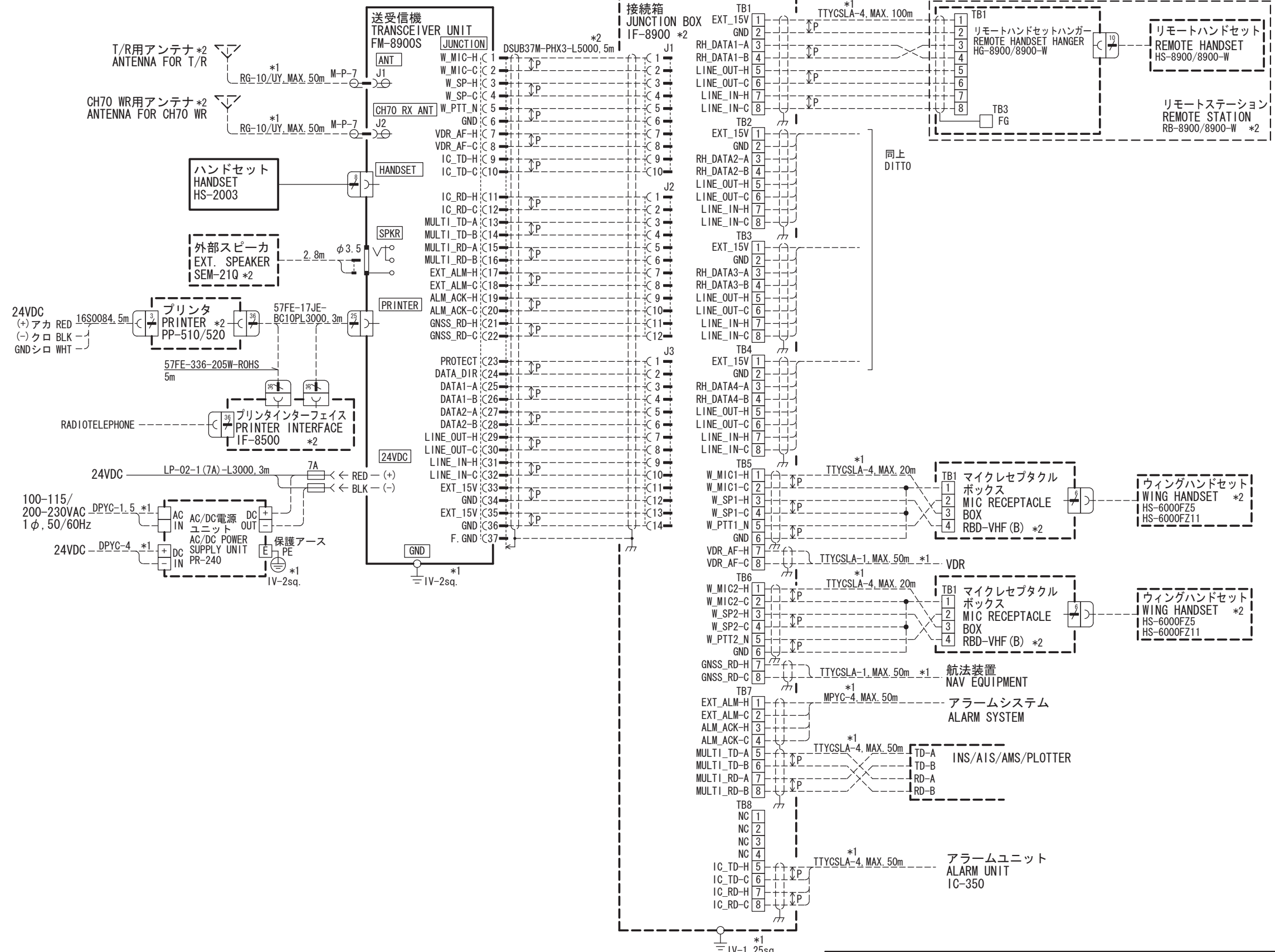

注記
 * 1) 造船所手配。
 * 2) オプション。

NOTE
 *1: SHIPYARD SUPPLY.
 *2: OPTION.

DRAWN	12/Mar/2013 T. YAMASAKI	TITLE	FM-8900S
CHECKED	12/Mar/2013 H. MAKI	名称	国際VHF無線電話装置
APPROVED	14/Mar/2013 Y. NISHIYAMA		相互結線図
SCALE	MASS kg	NAME	VHF RADIOTELEPHONE
DWG. No.	C5680-C01-F	REF. No.	05-104-2001-0
		INTERCONNECTION DIAGRAM	

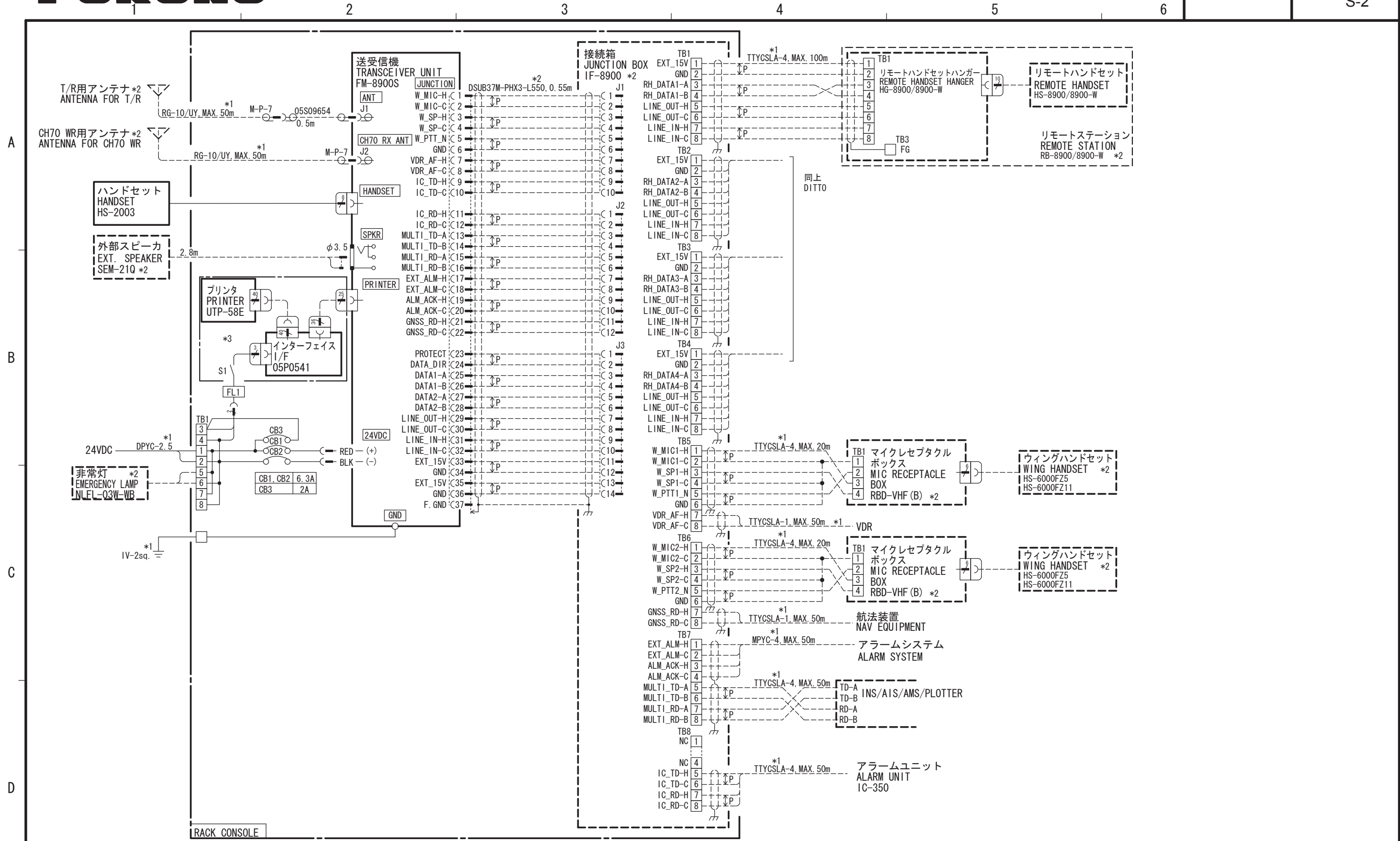

注記
 * 1) 造船所手配。
 * 2) オプション。
 * 3) Nタイプでは支給なし。

NOTE
 *1: SHIPYARD SUPPLY.
 *2: OPTION.
 *3: NOT SUPPLIED FOR RC-8900-N.

DRAWN 12/Mar/2013 T. YAMASAKI	TITLE RC-8900-A/N
CHECKED 12/Mar/2013 H. MAKI	名称 国際VHF無線電話装置(ラック組込)
APPROVED 14/Mar/2013 Y. NISHIYAMA	相互結線図
SCALE MASS kg	NAME VHF RADIOTELEPHONE (RACK CONSOLE)
DWG. No. C5680-C02-G	REF. No. 05-104-8001-0
INTERCONNECTION DIAGRAM	

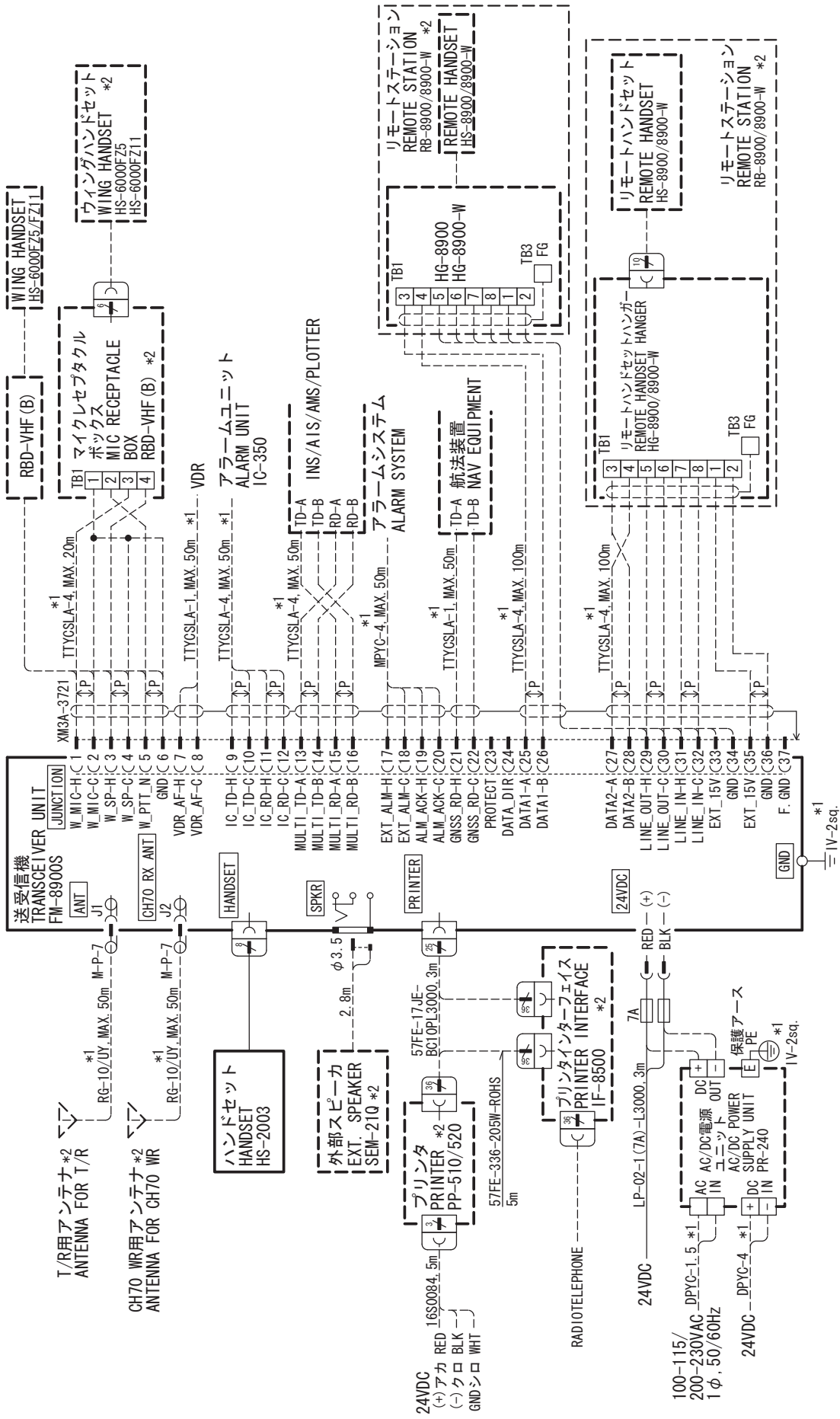

注記
 *1) 造船所手配。
 *2) オプション。
 NOTE
 *1: SHIPYARD SUPPLY.
 *2: OPTION.

DRAWN	12/Mar/2013	I. YAMASAKI	TITLE	FM-8900S
CHECKED	12/Mar/2013	H. MAKI	名称	国際VHF無線電話装置
APPROVED	14/Mar/2013	Y. NISHIYAMA	相互結線図	
SCALE	1/25	MASS	NAME	VHF RADIOTELEPHONE
DWG. No.	C5680-C03-F	kg	REF. No.	05-104-2001-0
			INTERCONNECTION DIAGRAM	